

OPERATOR'S MANUAL

Air-Operated Double Diaphragm Pump (1/2") SDS04-AAT-TATS-02

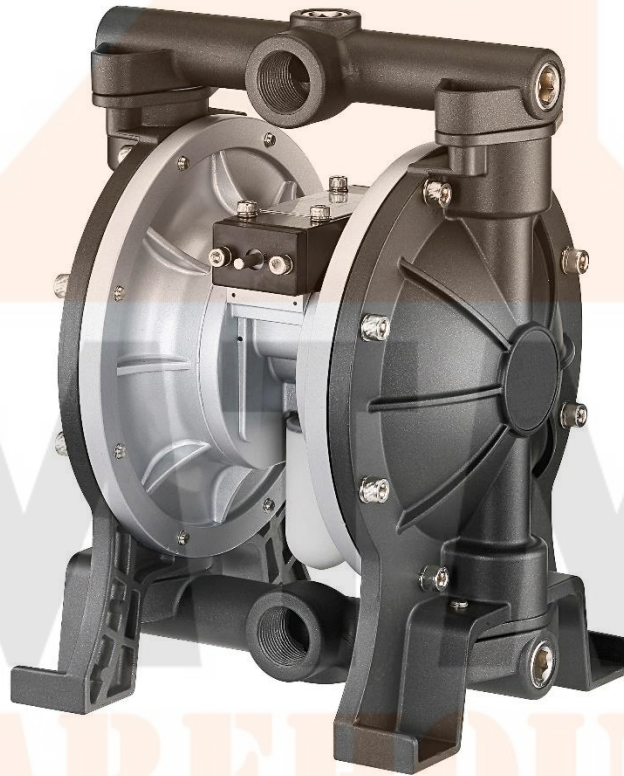

OPERATION, INSTALLATION & MAINTENANCE

PARTS LIST

****STOP****

READ THIS MANUAL CAREFULLY BEFORE INSTALLING, OPERATING OR SERVICING

THIS EQUIPMENT KEEP OFF THE LOSS UNNECESSARY.

Index

INSTALLATION AND CONFIGURATION	2
NOTICE OF OPERATION.....	3
NOTICE OF MAINTENANCE	3
CHECK REGULARLY.....	4
DIMENSIONS & PART LIST – SDS04-AAT-TATS-02.....	5

INSTALLATION AND CONFIGURATION

- Use the hose or soft tube to connect to the inlet and outlet. Reduces loss from vibration.
- Don't stamp or cause the hose to regulate pressure in the pump.
- Don't hang on the pump or else the pump will break.
- The suction head of inlet should be less than six metre (for water).
- When installing the pump, please use the following water vibration modes to absorb the vibration.
 - Installed Place – Install the pump horizontal and avoid installing on sloped surfaces.
 - Installed Aspect – Pay attention to keep the silencer's aspect down.
 - Installed Mode – When you firm up the pump, please install the buffer between the pump and base to avoid the pump from breaking.
- The direction for the inlet and outlet of the pipes can be tuned.
- When choosing the tube, consider the calibre, tolerance and pressure resistance. This helps to prevent the tube from breaking and leaking.
- Please check and clean the inside of the tube before installation. Check for any iron filling, trash or any other impurities inside. Otherwise, it may increase chance of the pump breaking.
- Choose the tube that will not break from negative feedback pressure when fluid transfers.
- Choose the correct tube size. Otherwise, insufficient suction if the tube is too big.
- It is recommended to install the filter in the inlet. It can help reduce the chance of the pump breaking and extends the life of the pump.
- For the high air pressure connection:
 - Don't use a tube too small in the air inlet.
 - Air pressure of inlet does not exceed 8.3kgf/cm² (bar).
 - Use the lubricant oil for cold-resistance and high-pressure resistance.
 - It is recommended to install the air filter regulator and lubricator (FRL) for the air inlet. It helps to supply clean air and lubricant oil.

NOTICE OF OPERATION

- Check the installation if they are correct before starting the pump. If the pump operates while there are any loose fasteners, it will cause damage to surrounding people and equipment.
- If the fluid is a flammable, it is recommended to link the ground wire to avoid chances of a fire or explosion from happening.
- Check the tightness of the inlet and outlet tube to ensure a stable link between the pump and tube. The fasteners should be tightened down to the correct torsion to be certain.
- When testing the pump before operation, the air inlet pressure should start at the lowest limit and then regulate the air pressure to the highest limit. Make sure the pump operation is normal and then regulate the air pressure to the value required.
- It is recommended to not let the pump idle for too long to avoid pressure loss and breakdown.
- It is recommended to regulate the air inlet pressure to control the flow rate first, and then gradually increase the fluid outlet switch slowly to the necessary value.
- When the pump is operating fluid filled inside and outlet switch is closed, then the pump will stop. This is not dangerous, but it is recommended to not hold this state for too long or have an operator beside. Otherwise, the fluid will leak.
- When stopping the pump, follow these instructions: close the inlet line for air, open the outlet switch and release the pressure remaining inside the pump and pipe.
- If you want to transfer the fluid which can precipitate or easily solidify, be sure to transfer the solvent to wash the pump inside after ceased operation. Otherwise, it can break the diaphragm and crack the thimble switch when the pump starts up next time.

NOTICE OF MAINTENANCE

- Please read this manual carefully before servicing the pump.
- Don't service the pump when it is operating o avoid causing endangering the operator.
- Before servicing the pump, follow these instructions: close the inlet line for air, open the outlet switch and release the pressure remaining inside the pump and pipe completely.
- Please use components produced from TONSON to service. Otherwise, it may cause breakdown or reduced in efficiency.
- It is recommended to be preserved and do yearly inspections.
- When tightening the fasteners, ensure the correct torsion. If the fastener is tightened greater or lesser than the necessary torque, it may cause the component to break or an accident.
- If any breakage, accident or breakdown because of what was stated above, the warranty is void.

CHECK REGULARLY

- Clean any impurities in the air-inlet filter regularly. Otherwise the impurities will reduce the efficiency or breakdown the pump.
 - If regular checks on the pump are neglected, the pernicious fluid will invade the stratochamber of the pump when the diaphragm breaks, and the pump will breakdown. Even cause an accident to surrounding people.
 - The diaphragm, ball valve, ball set and O-ring are all expendables. It is recommended to change them when the pump operates in stipulation number of times.
 - The life expectancy of diaphragm is almost ten million operations. (This is just an estimate. The life will cut down when the fluid has dust of metal, iron filings, wear-resisting particles or other foreign matter).
 - The O.D. of ball valve is shown below:
 - SDS03: 12.0mm SDS04: 15.9mm SDS06: 25.4mm
 - SDS10: 28.0mm SDS14: 45.0mm SDS20: 55mm
- If the O.D. of the ball is less than 95% or changes shape, then the check valve will reduce efficiency or stop working. It is then highly recommended to change the ball valve immediately.
- The ball seat and ball cover should be changed if there are signs of wear or changes shape. It is suggested for the ball valve to also be change simultaneously.

MTM
WAREHOUSE

DIMENSIONS & PART LIST – SDS04-AAT-TATS-02

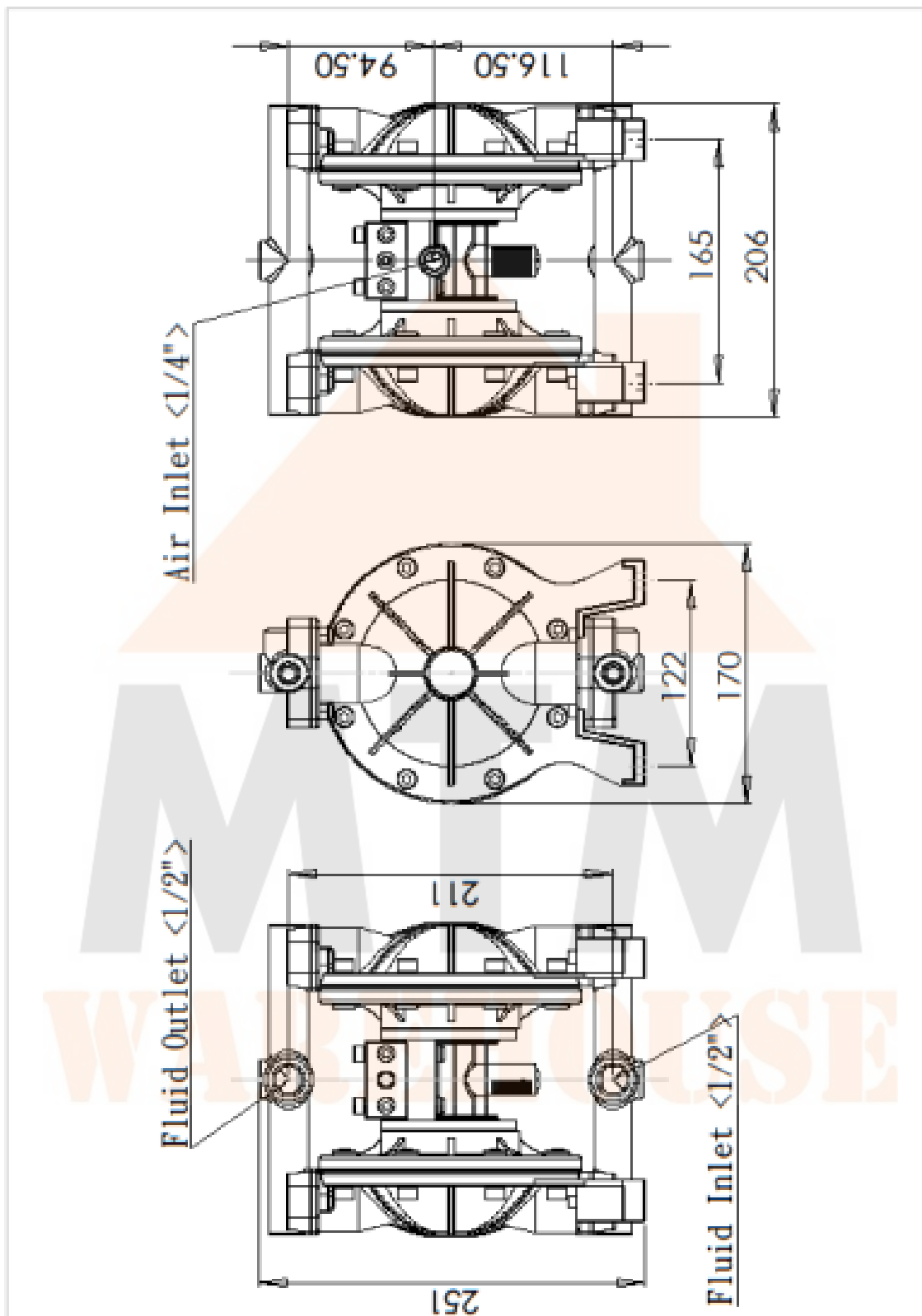

SDS04-AAT-TATS-02

Dissolution Drawing

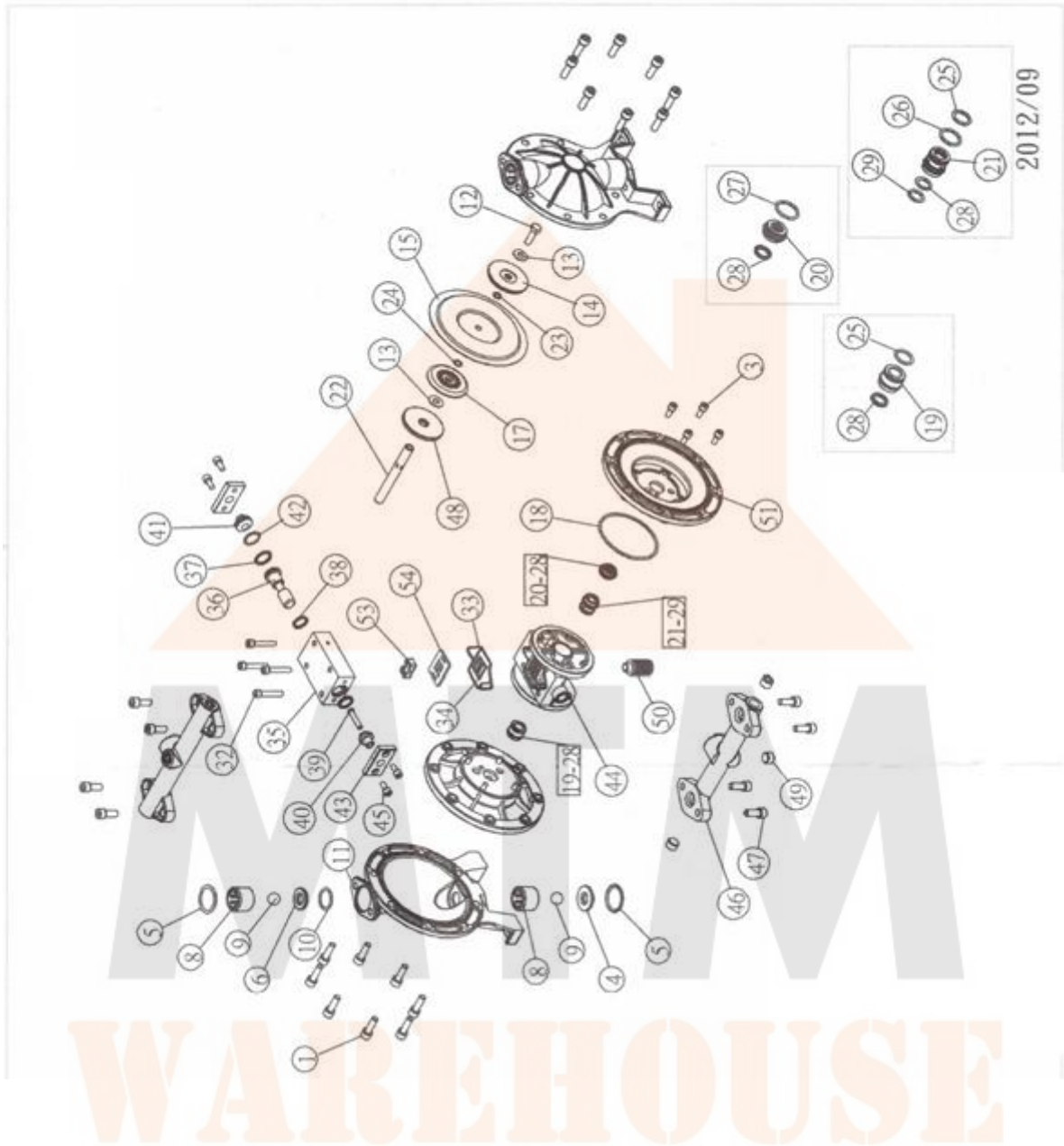

No.	Component Name	Component No.	Amount	No.	Component Name	Component No.	Amount
1	Hexagon Screw	PC000001SW	16	26	O-Ring	PD000050	1
3	Hexagon Screw	PC000004SW	8	27	O-Ring	PD000054	1
4	Down Ball Seat (SUS)	PA000014	2	28	U-Type O-Ring	PDAP0012	3
-	Down Ball Seat (PTFE)	PB000151	2	29	O-Ring	PD000003	1
5	Teflon O-Ring	PB000083	4	32	Hexagon Screw	PC000005SW	4
6	Up Ball Seat (SUS)	PA000026	2	33	Abnormal O-Ring	PD000140	1
-	Up Ball Seat (PTFE)	PB000150	2	34	Abnormal O-Ring	PD000139	1
8	Ball Cover (Collocate with Steel Ball)	PB000129	4	35	Body of Sequential	PA000102	2
-	Ball Cover (Collocate with Teflon Ball)	PB000127	4	36	Piston of Air Valve	PA000141	1
9	Steel Ball	PA000001	4	37	U-type O-Ring	PDAP0023	1
-	Teflon Ball	PB000039	4	38	U-type O-Ring	PDR00016	2
10	Pad	PB000013	2	39	Starting Copper Latch	PA000112	1
11	Housing of Pump	PA000047	2	40	Cover of Sequential-A	PD000080	1
12	Steel Hexagon Screw	PC000025	2	41	Cover of Sequential-B	PB000021	1
13	Steel Washer	PC000057	4	42	O-Ring	PD000035	1
14	Pad of Diaphragm	PA000059	2	43	Housing of Sequential	PA000117	2
15	Diaphragm (PE)	PB000032	2	44	Body of Cylinder Base	PA000143	1
-	Diaphragm (Teflon)	PB000026	2	45	Hexagon Screw	PC000004SW	4
17	Pad of Diaphragm	PA000059	2	46	Pipe	PA000131	2
18	O-Ring	PD000011	2	47	Hexagon Screw	PC000100SW	8
19	Shaft Cover-A	PB000170	1	48	Buffer Pad	PD000056	2
20	Shaft Cover-B	PB000173	1	49	Hexagon Bung	PC000413	6
21	Axis Switch	PA000150	1	50	Silencer	PB000046	1
22	Shaft of Diaphragm	PA000114	1	51	Air Pressure Room of Pump	PA000215	2
23	O-Ring	PB000001	2	53	Slithery Mass Valve	PB000334	1
24	O-Ring	PD000001	2	54	Include Ply	PB000072	1
25	O-Ring	PD000013	2				



Address: 5 Lyn Parade, PRESTONS, NSW 2170

E-mail: sales@mtmwarehouse.com.au

Telephone: (02) 9607 4300