



INTENDED USE KIT COMPOSITION	3
GENERAL SAFETY INSTRUCTIONS TO FOLLOW AT INSTALCTIONS	3
TOOLS	4
SAFETY AT INSTALATION	4
SPECIFICATIONS	5
ASEMBLY	6
MOUNTING	7
CONTROL UNIT	8
PROGRAMING	10
START	12
REPAIR	12
MAINTENANCE	12
NOTE	13

OPERATOR

SECTIONAL-750/1200/FAST-750



Installation and operating manual

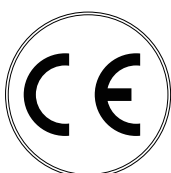

CONTENTS

INTENDED USE	3
KIT COMPOSITION	3
GENERAL SAFETY INSTRUCTIONS TO FOLLOW AT INSTALLATIONS	3
TOOLS	4
SAFETY AT INSTALLATION	4
SPECIFICATIONS	5
Dimensions	6
Description	6
ASSEMBLY	6
Pre-check	6
Connection of operator to guide	7
MOUNTING	7
External release (optional)	8
CONTROL UNIT	8
Specification	8
Wiring	9
Mounting of photocells (if they are included in the supply)	9
Installation	9
Maintenance	9
PROGRAMMING	9
Preparation	10
Top terminal position	10
Bottom terminal position	10
Automatic force adjustment	10
Force adjustment	10
Control button selection (заводская установка: 2)	10
Warning adjustment (factory preset: 0 – function is off)	10
Automatic closing (factory preset: 0 – function is off)	11
Actuation of audible warning signal after 2000 cycles (factory preset: 0 – function is off)	11
Programming completion	11
Remote control entry	11
Remote control delete	12
START	12
REPAIR	12
MAINTENANCE	12
DISPOSAL	12
MANUFACTURER'S WARRANTY	12
POSSIBLE MALFUNCTIONS AND TROUBLE SHOOTING	13
NOTE	14

This manual is for operators DOORHAN SECTIONAL

Automatic system SECTIONAL is intended for use with residential balanced gate (moderate use).

The system consists of an electromechanical motor-reducer, an electronic control unit and a light lamp, located in common case. This system is secured to ceiling and opens automatic gate by motion of chain. The system serves as lock when the gate is closed, but in case of power cut, the system can be released from inside or from outside and you can open the gate manually.

The operator has compulsory built-in protection to prevent entrapment.

The operator can be equipped with optional electronic safety sensors, which stop gate closing in case of an obstruction or people in automatic system coverage area.

Automatic system SECTIONAL is specially designed only for automatic control of sectional gate, do not use the system for other purposes.

KIT COMPOSITION

No	Name	Quantity
1	Operator	1
2	Radio control button	1
3	Curved bar	1
4	Supporting bracket	1
5	U-shaped bracket	3
6	Front bracket	1
7	Bracket for bar fastening	1
8	Operator shaft adapter	1
9	Guide assembly	1
10	Fastening elements	set

GENERAL SAFETY INSTRUCTIONS ON ITEM INSTALLATION

For safe operation of automatic gates do follow installation instructions contained in this manual.



- Improper installation can cause injury to people and damage to their property.
- Read carefully this manual before installation.
- Do not make any changes in the automatic system, which are not specified in this manual.
- Operator SECTIONAL is intended for automation of sectional gates. Do not use the operator for other than intended purposes.
- For fastening of the item, use hardware from operator kit or other analogous one.
- Check for conformity of the gates to the standards EN 12604 and EN 12605 (see documentation for gates). For countries, which are not EC members, the said measures are to follow in order to ensure standard safety level.
- Make sure, that the gate is well-balanced, runs smoothly and is equipped with mechanical end stops.
- If the drive is not to be used with doors having openings exceeding 10 mm in diameter or having edges or protruding parts a person could grip or stand on.
- **WARNING:** Important safety instructions. It is important for the safety of persons to follow all instructions. Save these instructions.

During installation:



- Use the tools, showed in section "Tools" of this manual.
- When performing operation at a height, use stable support.
- When drilling the holes, use protection for hands and eyes.
- Do not let children play during automatic opening of the gate.
- Check before starting the automatic system, that there is no obstruction in the automatic system coverage area.
- Before automatic opening of the gate, make sure, that the mechanical lock is open.
- If required, install the manual external release t a height about 180 cm.
- Install external control devices at a height not less than 150 cm, out of the automatic system coverage area, within visibility range.
- Maximal operator installation height is 450 cm. It is forbidden to install the operator at a height exceeding 450 cm. In case of installation at a height exceeding 250 cm, it is necessary to observe the rules of work at heights!

After installation is completed:



- Check safety sensors triggering at a height of 50 cm (if any obstruction within their coverage is detected or after touch with an obstruction, the gate will stop automatically or will open) and actuation of protection by force exceeding 20 kg.
- Use the automatic system SECTIONAL, following instructions from operating manual.
- Regularly have marks in servicing form done.
- The automatic system SECTIONAL does not require any special servicing.



IMPORTANT! RISK OF DAMAGE.

In case of supply cable damage, use the suitable type of the cable. Replacement of the cable shall be done by qualified personnel at the service centre.

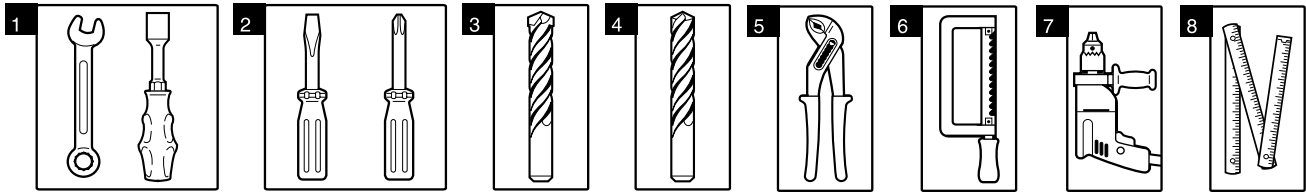
Tools required for installation of operator SECTIONAL:

- | | |
|--|--------------------------------|
| 1. Set of spanners | 5. Pliers |
| 2. Set of slotted and cross screwdrivers | 6. Hacksaw for metal |
| 3. Set of drills for metal | 7. Drilling machine |
| 4. Set of drills for concrete | 8. Tape measure (folding rule) |

Materials for installation of operator SECTIONAL and accessories (if available):

Cable 2×0.5 mm² (photocell transmitter, step-by-step control button)

Cable 4×0.5 mm² (photocell receiver)

Cable 2×1.5 mm² (supply)

Use the cables with voltage appropriate insulation.



Cables with voltage 230 V AC must be laid out by qualified technician.

Cablings shall have protective flutes, do not allow contact of cables and moving elements of the gate.

This operator complies with the requirements of European Directives 98/73/EC, 89/336/EC, 1999/5/EC

SAFETY AT INSTALLATION

1. **IMPORTANT!** Read carefully this manual to ensure safe installation and operation, improper installation and improper use can cause injury to people.
2. Before installation read carefully this manual.
3. Remove package of the item and dispose of it. Keep the package materials away from children.
4. Save this manual for future reference in case of maintenance during the whole operating period of the operator.
5. This product was designed for automation of sectional gates; its misuse can cause injury and health hazards.
6. DOORHAN shall not be held responsible in case of injury due to misuse of the item.
7. Do not install the equipment in premises containing quick inflammable substances or other dangerous environments, as it can cause explosion or fire.
8. Mechanical units of gates shall meet the requirements of the standards EN 12604 and EN 12605.
9. DOORHAN shall not be held liable in case of improper installation of the item and damage at operation.
10. Installation shall be performed in accordance with the standards EN 12453 and EN 12445. For countries, which are not EC members, the said measures are to follow in order to ensure standard safety level.
11. Switch off the power supply before installation and maintenance.
12. Mains supply shall be connected to the automatic system via automatic switch with a minimal distance of 3 mm between the neighboring contacts. It is recommended to use an automate 6A.
13. Safety devices of the operator protect against entrapment by closing the gate.
14. DOORHAN shall be not held responsible for unstable run of the automatic system when using safety devices and accessories, which are produced by other manufactures without agreement with DOORHAN.
15. It is highly recommended to use optional equipment DOORHAN, as the accessories, which are produced by other manufacturers, can damage the automatic system.
16. When carrying out maintenance, it is also recommended to use original spare parts DOORHAN.
17. Do not change components of the automatic system.
18. Be sure that after completion of installation the installer has shown the user how to release the gate in case of emergency and has instructed you on proper operation and maintenance of the automatic system.
19. Do not allow people to be present in the automatic system coverage area when the automatic system is working.
20. Never let children play in the area of or close to the moving gate and in the area of or close to the working operator. Keep all remote control units of operator and stationary control buttons away from children.
21. Passage is only allowed when the gate has stopped and the operator is off.
22. Repairs may be carried out only by qualified personnel, which was trained and certified at the authorized centre DOORHAN.
23. Check monthly good order state of the safety sensors (recommendation: use a wooden block with a height of 50 cm as an obstruction. This obstruction shall cause stopping of the gate or its opening).
24. Maintenance: make diagnosis of the system SECTIONAL at least half-yearly, the special attention shall be paid by check of the gate travel smoothness when in released state and operation of the release.
25. It is forbidden to carry out any actions, which are not allowed by this manual.

SPECIFICATIONS

Model	Sectional-750	Sectional-1200
Supply voltage range, V	180-240	
Current frequency, Hz	50	
Motor voltage (V dc)	24	
Maximum consumed power (W)	150	300
Force (H) max.	750	1200
Duty type	short-time duty — 5 minutes	
Light lamp (V ~/W)	230 / 25 max.	
Cartridge type	E14	
Lamp interrupting time (sec)	300	
Basic speed of slide (m/min)	6,6	
Corresponding safety device	Class 2	
Maximal gate width (mm)	5000	
Maximal gate height (mm)	depends on the guide used	
Guide working travel (mm)	2800	3800
Protection rate	for dry premises(IP20)	
Working temperature range (°C)	-20 / +55	
Fuse type	supply cutout fuse 1: 2.5A; lamp fuse 2: 2.5A: SR F2.5A (quick)	
Transmitter frequency/range	433 MHz/ on open site up to 50 m	
Operator type	chain	

DIMENSIONS

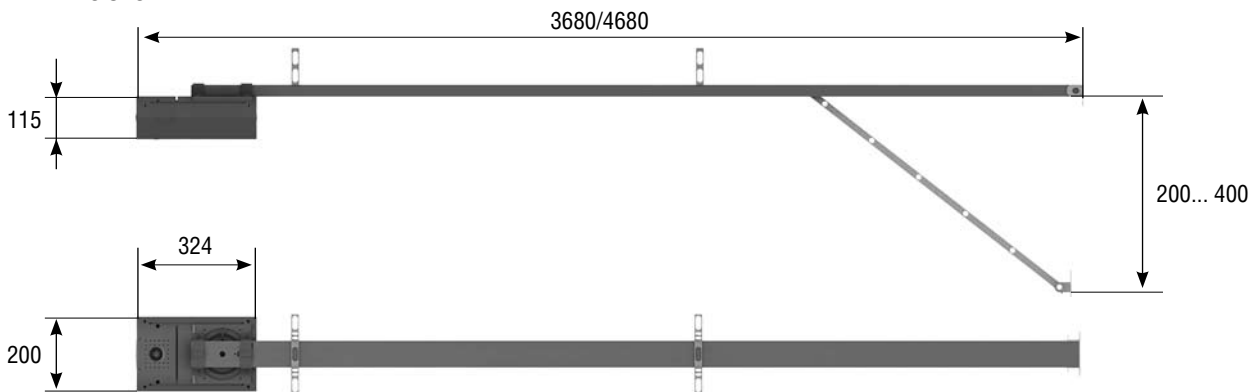

Operator	Recommended gate area (m ²)		
Sectional-750	<10		
Sectional-1200	<16		
Guide			
Model	G – Length	L – Working travel	Max. gate height
SK-3600	3620 mm	3400 mm	<2800 mm
SK-4600	4620 mm	4400 mm	<3800 mm

DESCRIPTION

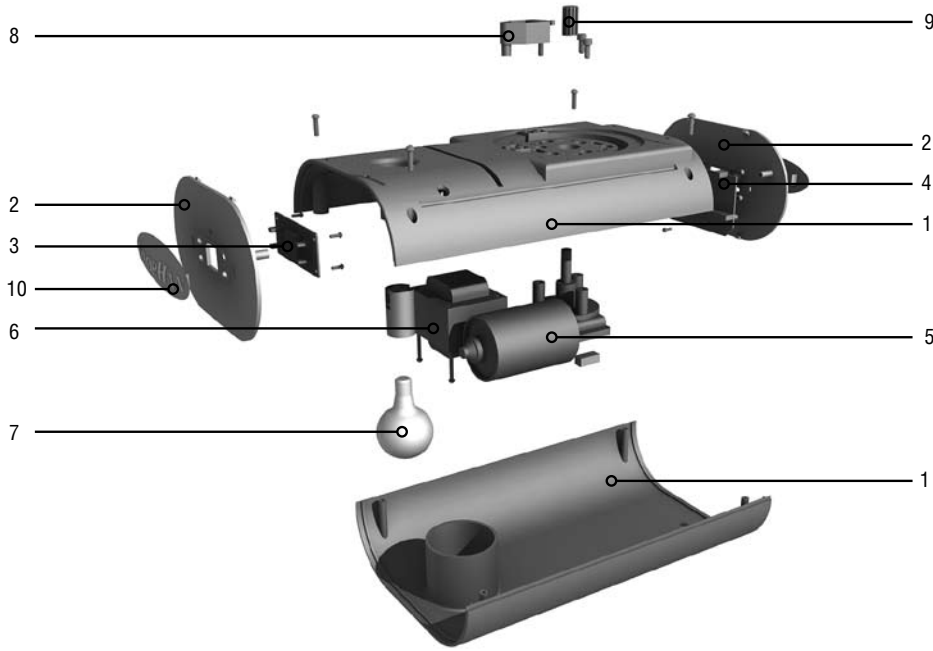

- 1. Case cover
- 2. Panel cover
- 3. Key panel
- 4. Control board
- 5. Motor-reducer
- 6. Transformer
- 7. Light lamp
- 8. Microswitch
- 9. Adapter
- 10. Protection cover

ASSEMBLY



Pre-check

Design of the gate shall meet the requirements of automation. In particular, check correspondence of the aperture dimensions with the dimensions, specified in the manual, as well as aperture material rigidity.

- Check for compliance of the gate with the standards EN12604 and EN12605 (refer to documentation for the gate).
- When the gate is moving, there shall be no vehicles, people and others within its coverage area.
- Check for good order state and intactness of the main moving units of the gate.
- Make sure, that the gate moves without jamming. If required, use special lubricant for cleaning and greasing of the parts of the guide, do not use fat.
- Check, if the gate is balanced and if the mechanical stops are installed.
- Check, that the mechanical door lock is open before using automatic control.
- Make sure, that the minimal clearance between the ceiling and the top point, when the gate is moving, is not less than 35 mm (Pic.4).
- Check, that the top roller of the gate leaf is in the vertical part of the guide rail, when the gate is completely closed (Pic.5).

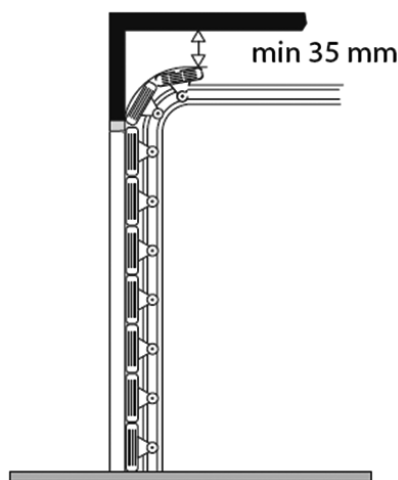

Pic. 4

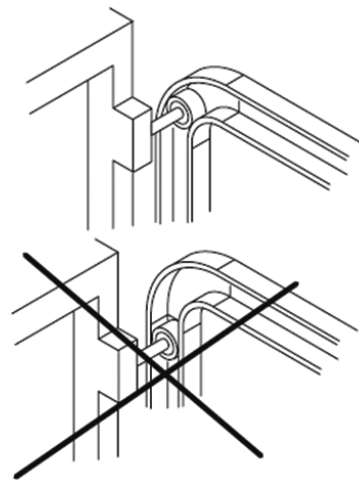

Pic. 5

CONNECTION OF OPERATOR TO GUIDE

Standard installation

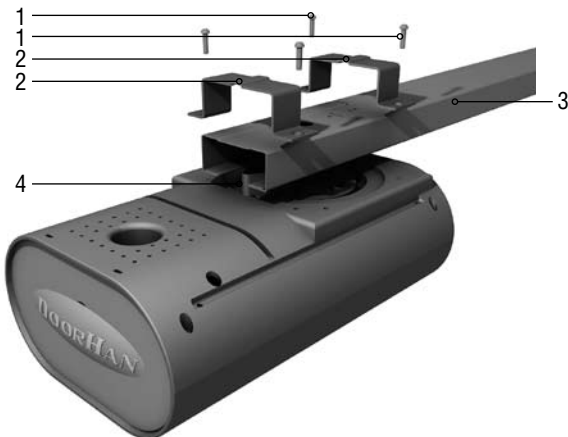

1. 6×15 tapping screws
2. U-shaped bracket
3. Guide
4. Microswitch

Non-standard installation

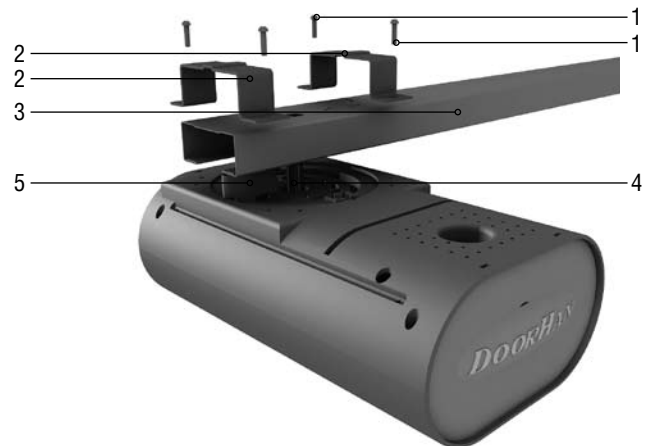

In non-standard installation is applied (see picture below), re-install the microswitch in a special place on the motor.

1. 6×15 tapping screws
2. U – shaped bracket
3. Guide
4. Operator bushing
5. Microswitch

INSTALLATION

Have only the certified personnel, which was trained at the authorized centres DOORHAN, carry out installation of the item.



- To ensure maximum safety, the operator shall be installed only, when the gate is closed.
- All operator fastening points must be used.
- Fastening of the brackets must be reliable to ensure proper rigidity.
- When drilling holes, an appropriate protection for hands and eyes shall be used.
- Read this manual to avoid mistakes by installation.

After pre-assembly has been completed, the vertical guide can be installed:

1. Mark on the ceiling a vertical line, which matches the centre of the gate horizontally.
2. Mark on the lintel a horizontal line in the place, where the gate by opening protrude upward to the maximum.
3. Fix the front roller so, that it is at least by 5 mm above the crossing of the marked lines. Follow instruction in par. 7.2 to secure the fastening brackets.
4. Mark 2 places for fastening.
5. Then drill and fasten using tapping screws.
6. Position the guide on the floor so, that it is transversely to the gate.
7. Secure the guide to the front bracket and to the ceiling.



MANUAL RELEASING AUTOMATIC SYSTEM

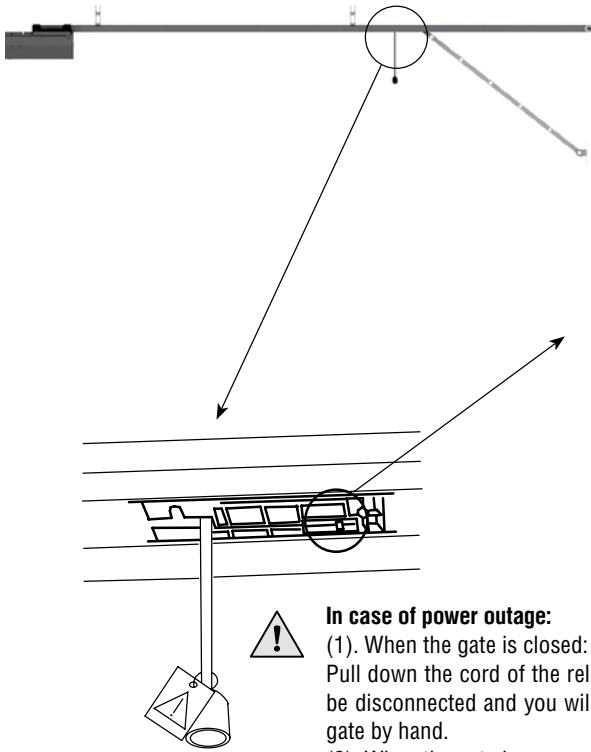

In case of power outage:

- (1). When the gate is closed:
Pull down the cord of the release, the slide will be disconnected and you will be able to lift the gate by hand.
- (2). When the gate is open:
Pull the cord of the release once, close carefully the gate until the slide will be connected.

In the case of power failure

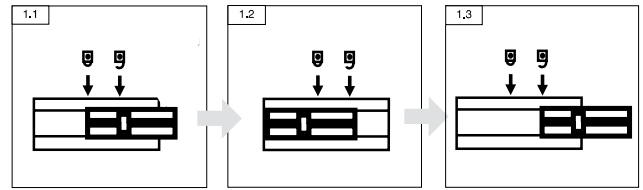

- (1). When the door is in closed position:
Pull down on the rope and dis-engage the clutch, this will allow the door to be lifted with easily.
- (2). When the door is in the open position:
Pull down on the rope once, this will allow the door to move downward to the closed position.

If power recovers

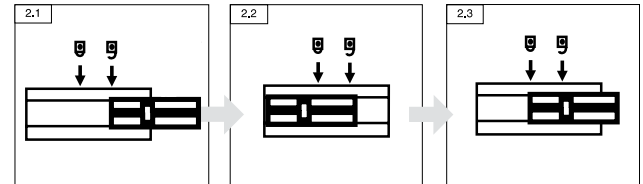

Operate the handheld transmitter or the wall control again, the clutch will be re-engaged automatically

After restoration of supply:

Give a control signal from the remote control or from the control button, the automatic system will resume its operation after restoration of supply.

External release (optional)

The external cable release is intended for manual emergency releasing the gate, when you are outside and when the power supply is cut off or the automatic system is out of order and you need access to the premises through the gate (if there is no wicket or other entry into the premises).



When installing the external release, use the appropriate instructions. It is recommended to use the external releases LOCK or LOCK N. In order to prevent damage of the automatic system, do not install releases, which are produced by other manufacturers!

CONTROL UNIT Specifications

Power supply (V ~ / Hz.)	230 / 50
Power supply of accessories (V dc)	24
Maximal current of accessories (mA.)	200
Working temperature range (°C)	-20 / +55
Radio control frequency	433 MHz
Operating logics	Automatic / Semi-automatic
Connectors	Open button/Safety devices
Lamp turn-on time (min)	3
Fuse type	quick, cutoff fuse, 230V, 2.5A, SR F2,5A



WIRING

IMPORTANT: Before beginning work with the operator (connection, maintenance), do always disconnect supply voltage.

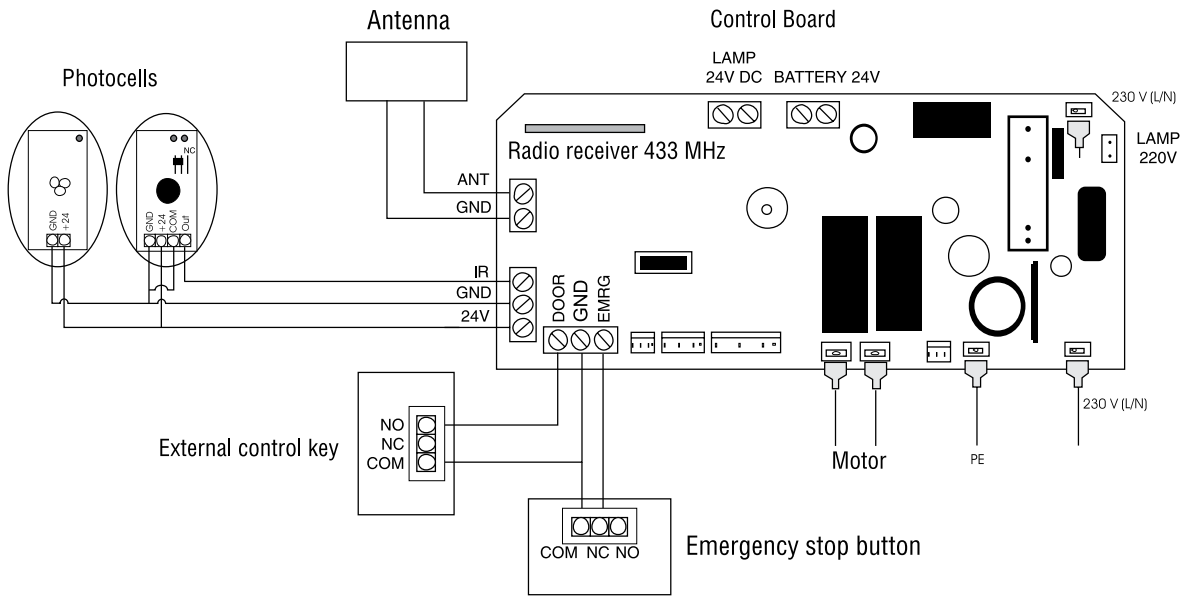

INSTALLATION OF PHOTOCELLS (IF SUPPLIED):

Installation



- Installation instruction:
- It is recommended to install them at a height above 20 cm, but not exceeding 2 m.
- The photocells shall be installed vertically and parallel one another.
- At first the receiver is installed, then the transmitter is installed.
- Remove the transmitter within the installation area until the photocells are parallel one another. At that the receiver turn-off lamp will go out, then fix the transmitter.
- Installation is completed.

Maintenance



- Due to nature of infrared radiation the system can work incorrectly, if the distance between the receiver and the transmitter is small. The distance between them shall not be less than 1 m. If sensitivity of the receiver by small distance between the receiver and the transmitter is not enough, remove the receiver lens, in order to increase its sensitivity.
- Avoid direct sun beams!
- Select the normal work mode of photocells in respect to control contacts : NO (normally opened) or NC (normally closed). If required, change the position of the jumper NC/NO.
- To ensure stable operation, a maximal distance between the photocells shall not exceed 25 m. If the weather is bad (fog, rain, dust etc.), the coverage area can decrease by 30%.

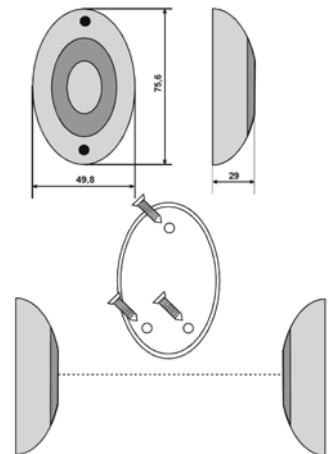

Recommendation by operation:



- Keep the photocells clean, if required, clean the external face of the sensors from dust and dirt.
- At least once a month check the correct operation of the photocells (if there is a hindrance between the photocells the gate must not close after a relevant command has been given and when the gate is moving to close it must reverse or stop)!



For use with the operator SECTIONAL, install the jumper for work with NO (normally opened) contacts on the photo.

PROGRAMMING

Preparation

Put the slide in locked state.

Turn on the power supply, an indicator on the operator will light up and a sound signal will be heard.

If the programming is not completed, the settings will not be saved. If there is a mistake in any of the settings, you can turn off the power and restart programming.



To get access to the programming panel, remove the protective cover by the face panel of the operator.

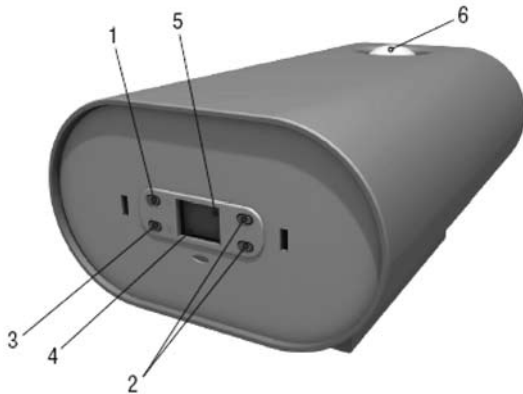

1. Radio code store key – «R»
2. Setting selection keys – «+», «-»
3. Programming key – «P»
4. Indicator of receiver signal coding key
5. Indicator of operator work and programming
6. Light lamp

Upper Limit Setting

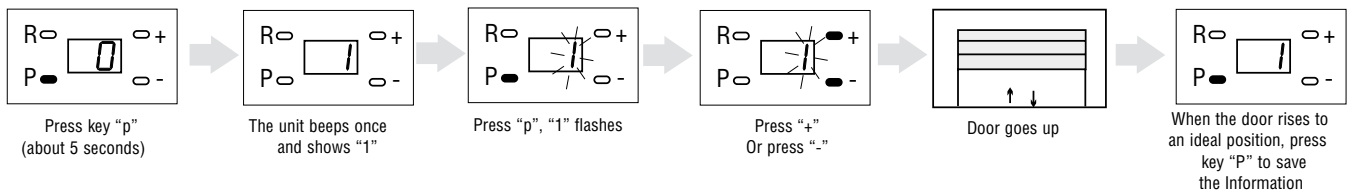

Down Limit Setting

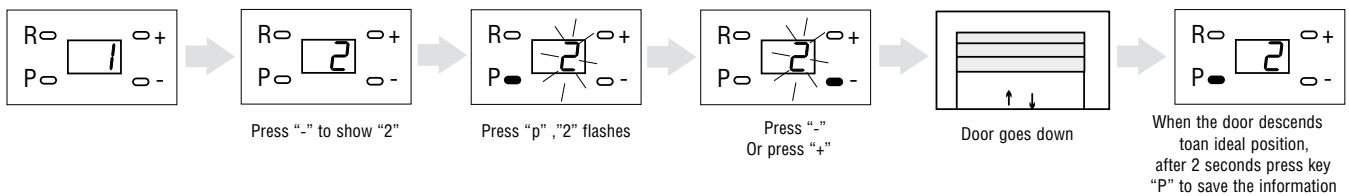

Operating Force Learning

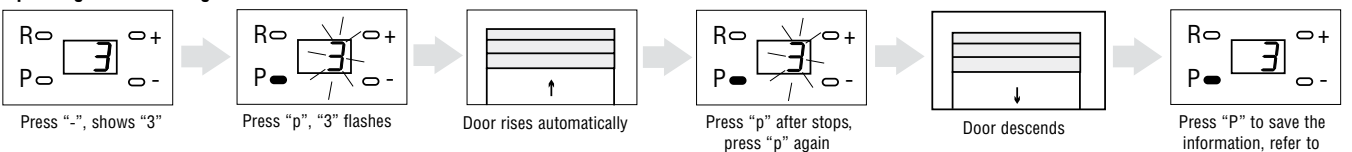

After the above basic settings, the user can now carry out the finalizing step to finalize the programming

Force Level Setting

The unit has been preset on the factory at level 4, resetting by end users is not required.

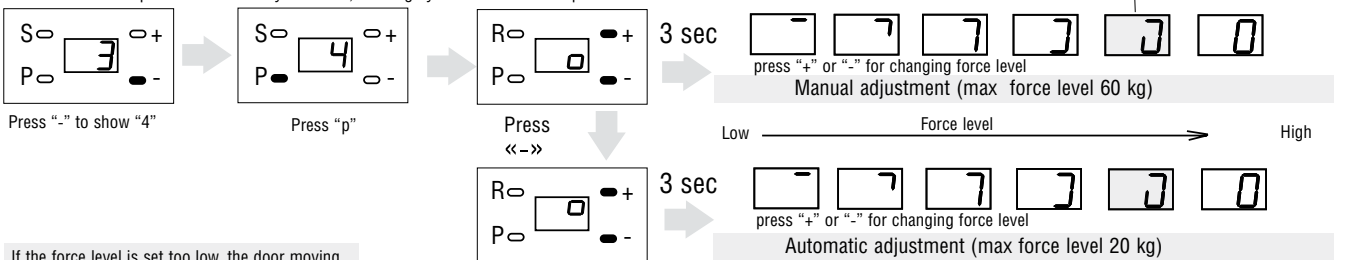

If the force level is set too low, the door moving will be affected when the mechanical structure of the door is not well-balanced

Press to "p" to save the settings

Alarm Settings

If the not closed in 10 minutes, system turns on alarm sound.

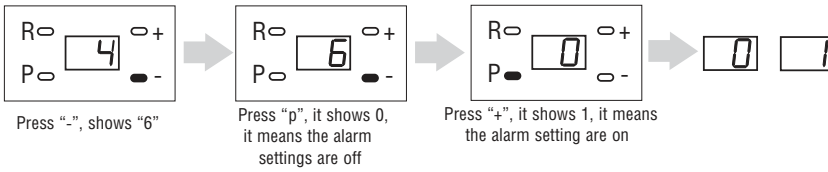

Automatic Closing Time Settings

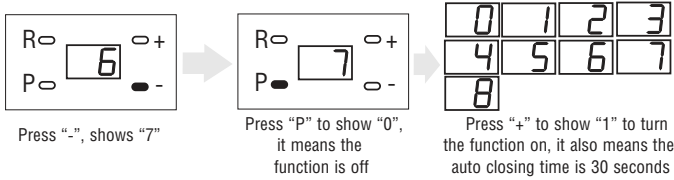

2000 Cycles Alarm Setting

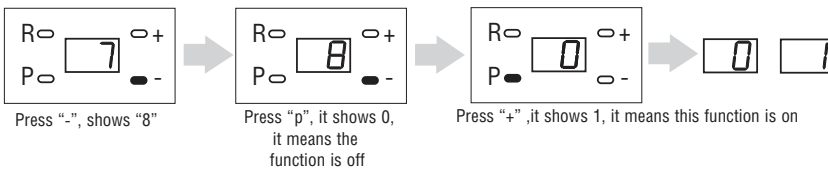

The inclusion of high speed opening/closing (only for FAST 750)

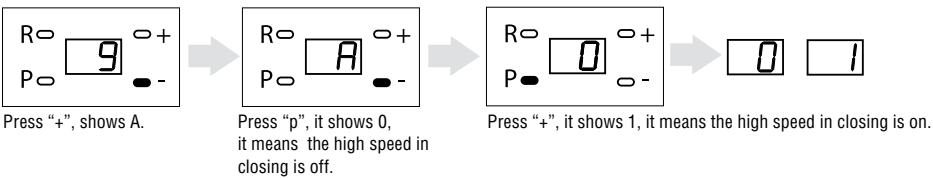
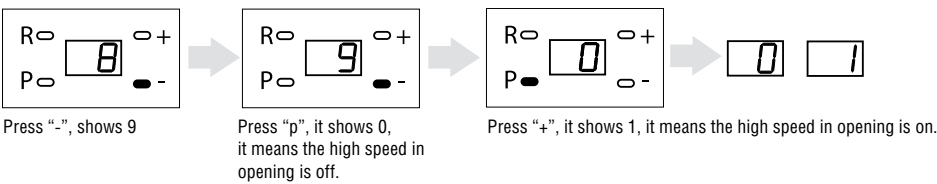

Final Programming

(NB: This finalizing step must be carried out, otherwise the saved information will be lost)

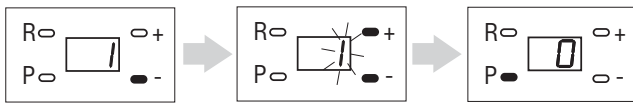

Programming of Transmitters

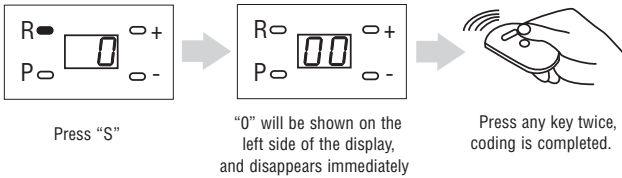

At this time, the code is successfully set if opener works. Other transmitters can be set as above.

All remote controls are entered one by one in the control unit. If the remote control is lost, delete radio codes and reprogram the remote controls to prevent unauthorized access.

START

Before start make sure, that the system works without jamming (release the slide, open and close the gate manually)
 Remote control – opening, closing and stop are performed by pushing one button on the remote control unit.
 Manual control – in case of power cut, the gate can be controlled by hand after releasing the slide.

Decode

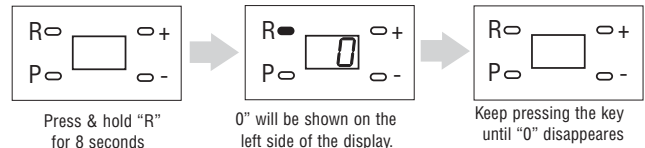

By now, no transmitters can operate the opener unless re-coded.

For security purpose if a transmitter has been lost the opener must be decoded and the new transmitter encoded as above, so that the lost one can not operate the door anymore.



REPAIRS

If the gate requires repairs, contact the authorized centres DOORHAN.



MAINTENANCE

- Maintenance shall be carried out by the personnel, which was trained and certified at the authorized centre DOORHAN. Replacement of fuses shall be performed by the personnel, which is certified to perform electric operations.
- The light lamp shall be replaced only after the operator is disconnected from mains.
- The operator Sectional-750 – is a mechanism, that requires minimal maintenance.
- Check regularly mechanics of the gate (balance), the gate travel smoothness by automatic control.
- Check regularly proper adjustment of extreme positions, functionality and capacity of safety devices. Lubricate the moving parts.
- In case of power cut you may need to restore operator's settings. For that, after restoration of power supply carry out one complete cycle of opening/closing the gate:
- After power cut the gate will stop.
- After the power restoration, push the button on the remote control.
- The gate will move up and stop in accordance with the programmed position.
- Check functionality of the system at least every 6 months, pay special attention to the safety devices and the release.

DISPOSAL



Before disposal of the automatic system, remove and then dispose of the protective package of the operator! Remember unutilized package can be hazardous for people.

After expiration of life time, the item shall be delivered in a specialized disposal point!

MANUFACTURER'S WARRANTY

Manufacturer's warranty is 3 years from the date of sale of the item.

The warranty does not cover the following cases:

- Improper installation without following the recommendations of the manufacturer, which are specified in this manual.
- Performance of installation by the unqualified personnel, which was not certified at the authorized centre DOORHAN.
- If the servicing was carried out in the centres, which are not authorized service centres DOORHAN.
- Unauthorized interference in the operator's adjustments, connection of accessories and disassembling.
- Connection and use of accessories, produced by other manufacturers without agreement with the manufacturer.
- Other cases, provided for by the law of the country of the manufacturer.



POSSIBLE MALFUNCTIONS AND TROUBLE SHOOTING

To avoid electrical shock all operations on setting and connection shall be carried out by the qualified and licensed personnel.

Malfunction	Possible reason	Solution
Operator does not run	1. No power 2. Fuse is damaged	1. Turn on the power 2. Replace the fuse
Gate can not be opened from the remote control	1. Remote control code is not entered 2. Battery in remote control is discharged	1. Reenter the remote control 2. Replace the power battery
Remote control coverage area is too small	Battery in remote control is discharged	Replace the battery
Guide chain moves and gate does not move	Slide is released and not connected to chain support	Match the slide with the support and connect the slide
Warning sound signal is on	1. Gate is opened 2. Warning sound signal after 2000 cycles to perform maintenance	1. Close the gate 2. Turn of the power and turn on it again
Gate does not reach terminal positions or does not work	Error by programming	Perform programming
Gate work with troubles, on indicator the "H" lights	Electronics failure due to high humidity	Clean the control board (this operation shall be done by technician)
Gate stopped suddenly, on indicator the "F" lights	1. Gate touched the obstruction or mechanics was jammed. 2. Unstable power supply	1. Check the gate mechanics, remove obstruction 2. Check supply voltage
Squeak during system operation	Guide chain is not enough lubricated after long-run use	Lubricate the chain
Chain makes noise and rubs guide	Chain became too long	Lubricate the cog wheel of the chain and tension the chain

