

D5 SMART INSTALLATION MANUAL



D5 SMART



Contents



This icon indicates tips and other information that could be useful during the installation.

1. INTRODUCTION	Page 5
1.1. Important Safety Information	Page 6
1.2. Lightning Protection	Page 8
1.3. Theft Protection	Page 8
2. SPECIFICATIONS	Page 9
2.1. Physical Dimensions	Page 9
2.2. Technical Specifications	Page 9
3. PRODUCT IDENTIFICATION	Page 11
4. REQUIRED TOOLS AND EQUIPMENT	Page 12
5. NEW SITE INSTALLATION PREPARATION	Page 13
5.1. General Considerations for the Installation	Page 13
5.2. Endstops	Page 14
5.3. Guide-rollers and Anti-lift Brackets	Page 14
5.4. Starting and Running Forces	Page 15
5.5. Cabling Requirements	Page 16
6. LUBRICATION	Page 17
7. OPERATOR INSTALLATION	Page 18
7.1. New Site Installations	Page 18
7.1.1. Locating an Initial Reference Point	Page 18
7.1.2. Minimum Clearances	Page 19
7.1.3. Locate the Operator's Position	Page 20
7.1.4. Foundation Plate Installation	Page 24
7.2. Retro-fit Installations (Existing Sites)	Page 26
7.3. Conduit and Cable Length	Page 26
7.4. Preparing the D5 SMART for Installation	Page 27
7.4.1. Removing the Charger	Page 27
7.4.2. Removing the Lower Battery Tray	Page 28
7.4.3. Removing the Control Card	Page 29
7.5. Mounting the Gearbox	Page 30
7.6. Routing the Cables	Page 32
7.7. Manual Override	Page 34

7.8. Height Adjustment	Page 35
7.9. Mounting the Rack	Page 36
7.9.1. Fitting Different Types of Rack to the Gate	Page 37
7.9.2. Finalising the Height Adjustment	Page 40
7.10. Re-assembling the D5 SMART	Page 42
7.10.1. Override Sensor	Page 42
7.10.2. Routing the Override Sensor Harness	Page 42
7.10.3. Placing the Lower Battery Tray and Charger back into Position	Page 43
7.10.4. Placing the Control Card back into Position	Page 44
7.10.5. Reconnecting the Harnesses to the Control Card and Charger	Page 45
8. COMPLETING THE INSTALLATION	Page 46
8.1. Fitting the Batteries	Page 46
8.2. Accessory Installation and Storage	Page 47
8.3. Wiring the Control Card on its Default Settings	Page 48
8.3.1. Closing Infrared Beam Wiring (i5 Infrared Beams)	Page 48
8.3.2. Closing Infrared Beam Wiring (Photon Infrared Beams)	Page 49
8.3.3. External Radio Receiver and Loop Detector Wiring	Page 50
8.3.4. Anti-tamper Alarm with two Wizo's Wiring	Page 51
8.4.5. Solar Panel Wiring	Page 52
8.3.5. Earth Spike Installation	Page 53
8.3.6. G-ULTRA to D5 SMART Wiring	Page 54
8.4. Commissioning the System	Page 54
8.5. Apply Warning Decal	Page 55
9. GENERAL MAINTENANCE	Page 56
9.1. Gate Maintenance	Page 56
9.2. D5 SMART Maintenance	Page 57
10. INSTALLATION HANDOVER	Page 58
11. WARRANTY INFORMATION	Page 59

Icons used in this manual



This icon indicates tips and other information that could be useful during the installation.



This icon denotes variations and other aspects that should be considered during installation.



This icon indicates warning, caution or attention! Please take special note of critical aspects that MUST be adhered to in order to prevent injury.

1. Introduction

The **D5 SMART** is a domestic and light-industrial operator designed to open and close sliding gates weighing up to 500kg. A custom-designed gearbox moulded from robust engineering polymers, coupled to a powerful 24V DC motor, provides fast and reliable automation for entrances to homes and small housing estates.

The system operates off two 12V batteries housed inside the operator using a switch-mode charger to maintain the battery in a fully-charged state. The batteries provide critical power failure protection.

A non-contact Hall Effect Sensor was selected to ensure reliability and positional accuracy. The Hall Effect Sensor is highly resistant to dust, oil, dirt or insect ingress, therefore ensuring that the **D5 SMART** opens and closes gates reliably and accurately.

Advanced features of the D5 SMART logic controller include:

- Interactive graphic user interface via a smartphone application
- Automated setup of gate endpoints (limits)
- Independently-adjustable motor speed in both opening and closing directions
- Fail-safe collision detection and auto reverse (adjustable sensitivity)
- Smooth, adjustable start/stop (ramp-up/ramp-down)
- Multiple operational modes
- Selectable, adjustable Autoclose
- Pedestrian (partial) opening
- Positive Close Mode
- Independent safety inputs for opening and closing beams
- Automatic beam test for both opening and closing beams
- Advanced lightning/surge protection
- Onboard NOVA code-hopping radio receiver with full channel-mapping capability (limited to 1500 remotes¹)

1. Multiple buttons per remote can be used

1.1. Important Safety Information



ATTENTION!

To ensure the safety of people and possessions, it is important that you read all of the following instructions.

Incorrect installation or incorrect use of the product could cause serious harm to people.

The installer, being either professional or DIY, is the last person on the site who can ensure that the operator is safely installed and that the whole system can be operated safely.

Warnings for the Installer

CAREFULLY READ AND FOLLOW ALL INSTRUCTIONS before installing the product.

- All installation, repair, and service work to this product must be carried out by a suitably qualified person
- This appliance is not intended for use by persons (including children) with reduced physical, sensory or mental capabilities, or lack of experience and knowledge, unless they have been given supervision or instruction concerning use of the appliance by a person responsible for their safety
- Do not activate your gate unless it is in view and you can determine that its area of travel is clear of people, pets, or other obstructions
- **NO ONE MAY CROSS THE PATH OF A MOVING GATE —**
always keep people and objects away from the gate and its area of travel
- **NEVER LET CHILDREN OPERATE OR PLAY WITH THE GATE CONTROLS**
- Secure all easily-accessed gate opener controls in order to prevent unauthorised use of the gate
- Do not in any way modify the components of the automated system
- Do not install the equipment in an explosive atmosphere: the presence of flammable gases or fumes is a serious danger to safety
- Before attempting any work on the system, turn off electrical power to the operator and disconnect the batteries
- The Mains power supply of the automated system must be fitted with an all-pole switch with contact opening distance of 3mm or greater; use of a 5A hydraulic breaker with all-pole circuit break is recommended
- Make sure that an earth leakage circuit breaker with a threshold of 30mA is fitted upstream of the system
- Never short-circuit the battery and do not attempt to recharge the batteries with power supply units other than that supplied with the product, or manufactured by Centurion Systems (Pty) Ltd

- Make sure that the earthing system is correctly constructed and that all metal parts of the system are suitably earthed
- Safety devices must be fitted to the installation to guard against mechanical movement risks such as crushing, dragging and shearing
- Always fit the warning signs visibly to the inside and outside of the gate
- The installer must explain and demonstrate the manual operation of the gate in case of an emergency and must hand over the User Guide/Warnings to the user
- The installer must explain these safety instructions to all persons authorised to use this gate, and be sure that they understand the hazards associated with automated gates
- Do not leave packing materials (plastic, polystyrene, etc.) within reach of children as such materials are potential sources of danger
- Dispose of all waste products like packing materials, worn-out batteries, etc., according to local regulations
- Always check the obstruction detection system, and safety devices for correct operation
- Neither Centurion Systems (Pty) Ltd, nor its subsidiaries, accepts any liability caused by improper use of the product, or for use other than that for which the automated system was intended
- This product was designed and built strictly for the use indicated in this documentation; any other use, not expressly indicated here, could compromise the service life/operation of the product and/or be a source of danger
- Everything not expressly specified in these instructions is not permitted



1.2. Lightning Protection

The electronic controller utilises the same proven surge protection philosophy that is used in all our products. While this does not guarantee that the unit will not be damaged in the event of a lightning strike or power surge, it greatly reduces the likelihood of such damage occurring. The earth return for the surge protection is provided via the mains power supply earth and/or earth spike located next to the operator.



In order to ensure that the surge protection is effective, it is essential that the unit is properly earthed.

1.3. Theft Protection

While care has been taken in the design of the **D5 SMART** to prevent unauthorised removal (theft) of the unit, an optional steel theft-deterrent cage is also available for added peace of mind.



If a theft-deterrent cage is required, be sure to leave enough clearance from pillars, etc. (Section 7.1.2. - "Minimum Clearances").

2. Specifications

2.1. Physical Dimensions



FIGURE 1. D5 SMART PHYSICAL DIMENSIONS

2.2. Technical Specifications

Input voltage¹	90V - 240V AC +/-10% @ 50Hz ¹
Current consumption (mains)	200mA
DX1 Battery charger current output	1.3A@ 27.4V +/-1%
Maximum number of operations per day	150 ^{3,6}
Duty cycle - Mains present^{2,3}	50%
Motor power supply	Battery-driven (Standard Capacity - 2x12V)
Current consumption (motor at rated load)	13A
Input / Output sink currents (Max. accessory current draw)	
I/O 1-4	100mA (12/24V)
I/O 5 and 6	3A (12/24V) 10sec Pulse

TABLE 1

2.2. Technical Specifications Continued

Fuse Protection	Type		Rating	
Main Control Card	Serviceable		25A	
Aux. Supply	Resettable Fuse		12V 600mA or 24V 3A (10sec Pulse)	
Charger (Mains Supply)	Non-serviceable		3A slow-blow	
Motor push force - starting	30kgf			
Motor push force - rated	17kgf			
Gate mass - maximum	500kg			
Gate length - maximum	100m			
Gate speed (varies with load)⁴	Up to 35m/min @ 17kgf			
Manual Override	Lockable with key release			
Operations whilst in battery backup mode with 7.2Ah batteries	Operating Mode			
	Power Saving 15m/min 7kgf	Power Saving 15m/min 17kgf	Normal 30m/min 7kgf	Normal 30m/min 17kgf
	Half day ^{5,6}	209	96	102
Full day ^{5,6}	183	87	79	59
Operations whilst in battery backup mode with 7Ah 28 W batteries	Operating Mode			
	Power Saving 15m/min 7kgf	Power Saving 15m/min 17kgf	Normal 30m/min 7kgf	Normal 30m/min 17kgf
	Half day ^{5,6}	197	87	70
Full day ^{5,6}	170	75	45	30
Collision Sensing	Electronic			
Operating temperature range	-15°C to +50°C			
Onboard receiver type	Code-hopping multichannel receiver with selective add and delete			
Receiver code storage capacity	1500 Remotes ⁷			
Receiver frequency	433.92MHz			
Degree of protection	IP55			
Mass of unit packed (with standard kit, but excl. rack and battery)	9.1kg			
Packaging dimensions (with standard kit, but excl. rack and battery)	325mm wide x 244mm deep x 445mm high			

TABLE 1 CONTINUED

1. Can operate off a solar supply, consult your local dealer for assistance

2. Based on 25°C ambient temperature and unit not in direct sunlight

3. Based on a motor push force of less than 50% of rated (Starting and Running forces)

4. Gate opening and closing speeds can be configured to run slower depending on the requirements of individual installations

5. Can increase battery capacity for longer standby times

6. Based on 4m gate, excluding all accessories

7. Multiple buttons per remote can be used

3. Product Identification

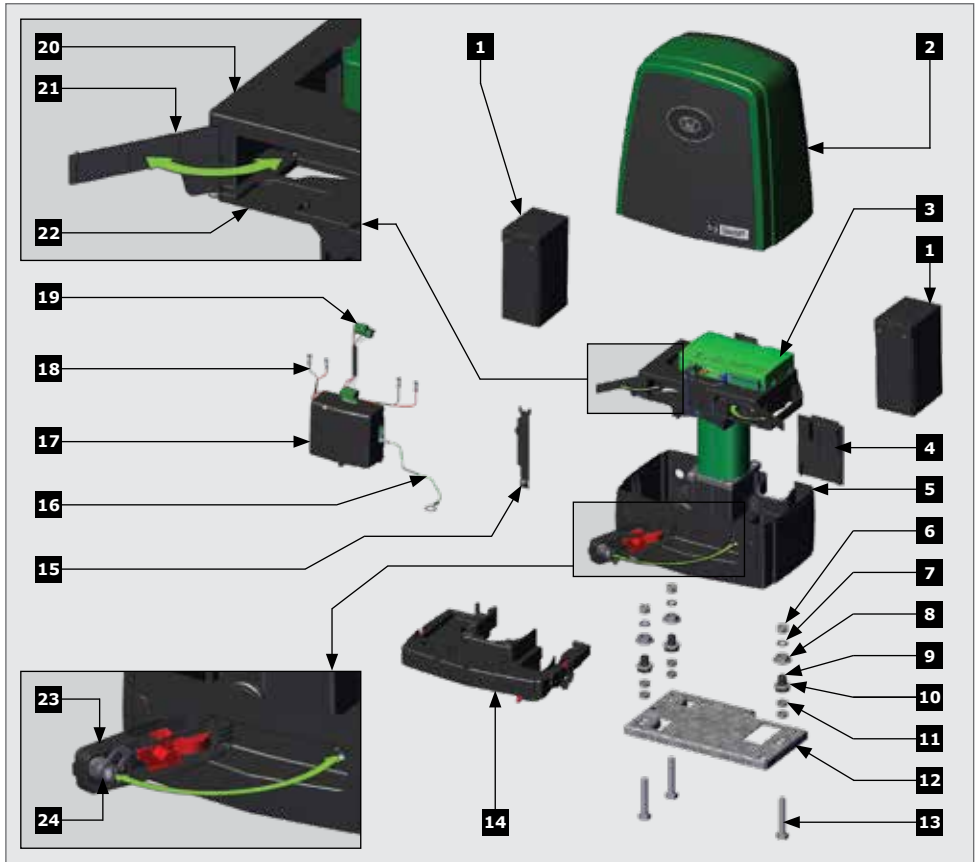

FIGURE 2. PRODUCT IDENTIFICATION

- | | |
|--------------------------------------|------------------------------|
| 1. 12V Battery ¹ | 13. Mounting Bolt |
| 2. D5 SMART Cover | 14. Lower Battery Tray |
| 3. DX Control Card | 15. Cable Trunking |
| 4. Cable Shield | 16. Earth Harness |
| 5. Gearbox | 17. Switch Mode 1.3A charger |
| 6. M10 Nut (17mm Socket) | 18. Battery Harness |
| 7. Spring Washer | 19. Power Supply Harness |
| 8. Top Height Adjuster (19mm Socket) | 20. Accessory Tray |
| 9. Bottom Height Adjuster | 21. Accessory Retaining Door |
| 10. Heavy Duty M12 Washer | 22. Top Battery Stabiliser |
| 11. M10 Half-Nut | 23. Release Handle |
| 12. D5 SMART Foundation Plate | 24. Camlock |

1. Batteries are not supplied with the **D5 SMART**. The **D5 SMART** supports both 6Ah and 7.2Ah variants.

4. Required Tools and Equipment



FIGURE 3. REQUIRED TOOLS AND EQUIPMENT

5. New Site Installation Preparation

5.1. General Considerations for the Installation

Always recommend the fitment of additional safety equipment such as safety edges and safety beams, for additional protection against entrapment or other mechanical risks.

Check that no pipes or electrical cables are in the way of the intended installation.

Check that enough space is available for the gate operator, specifically for the release handle (See Section 7.1.2. - "Minimum Clearances").

Check for loose, sandy soil if installing a foundation, as the soil condition may require a larger foundation.

Never fit the operator on the outside of the gate, where the public have access to it.

Install the gate operator only if:

- It will not pose a hazard to the public
- There is sufficient clearance to a roadway and/or public thoroughfares
- The installation meets all municipal and/or local authority requirements once completed
- The gate mass and application are within the operator specifications
- The gate is in good working order, meaning:
 - that it opens and closes freely;
 - does not move on its own if left in any position;
 - it can be installed to have sufficient clearance between moving parts when opening and closing to reduce the risk of personal injury and entrapment;
- Pushbuttons or key-switches, when required, can be positioned so that the gate is in line-of-sight of the user

5.2. Endstops

Fit opening and closing endstops capable of stopping the gate at rated speed. Refer to the specifications at the beginning of this manual for the operating speed.

Make $H1 > H2$ to ensure gate will not jump over the endstop.

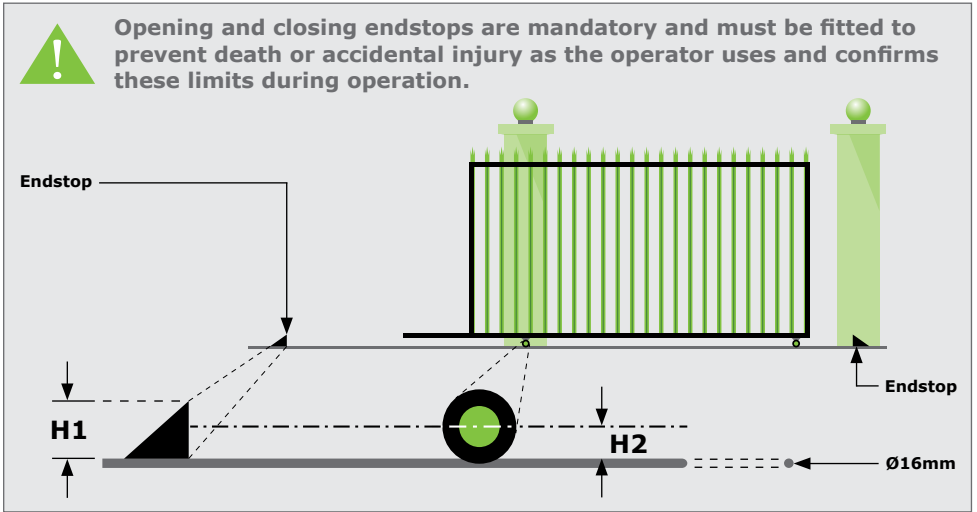

FIGURE 4. FITTING ENDSTOPS

5.3. Guide-rollers and Anti-lift Brackets

Guide-rollers must be installed to ensure that the gate is held vertical. For improved safety, fit additional support posts to prevent the gate from falling over should the guide-rollers fail.

To prevent unauthorised access, fit anti-lift brackets as shown.

The gap between the anti-lift bracket and the gate must be less than 5mm.



Ensure that the gate cannot be lifted off the motor pinion with the anti-lift bracket fitted.

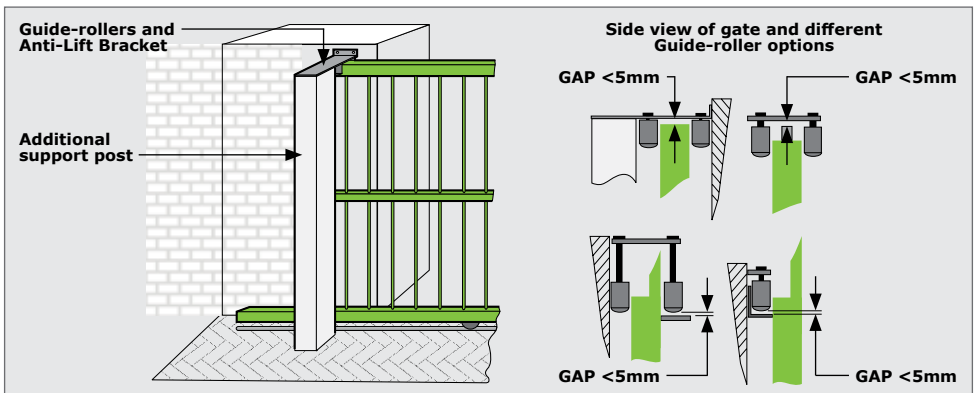

FIGURE 5. FITTING GUIDE-ROLLERS

5.4. Starting and Running Forces

Test the starting force of the gate as per the diagram. Use a pull scale in both directions to determine the maximum amount of pull force required to set the gate in motion.

Determine the running force of the gate by continuing to pull on the scale with just sufficient force to keep it running.

Read and note the maximum value in kgf (kilogram-force) shown on the scale.

Where possible, determine the gate mass.

Our warranty will be void if the pull force and / or gate mass exceeds the below operator specifications:

- Starting force - 30kgf
- Running (rated) force - 17kgf
- Maximum gate mass - 500kg

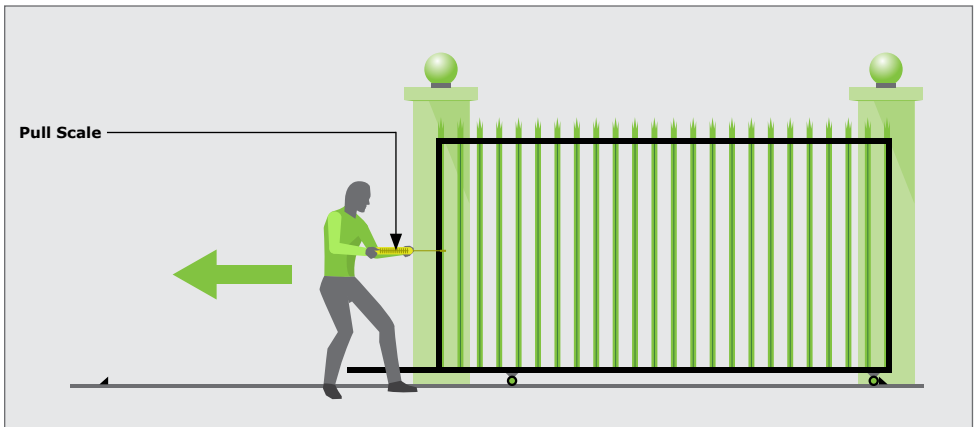

FIGURE 6. STARTING AND RUNNING FORCES

5.5. Cabling Requirements

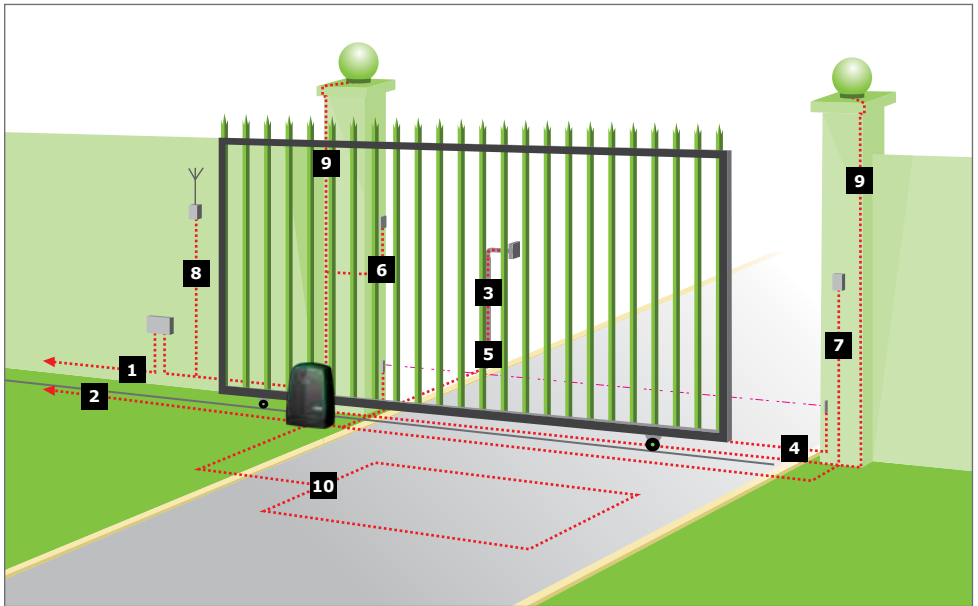

FIGURE 7. CABLING REQUIREMENTS

Legend

1. **MAINS SUPPLY CABLE:** 90V - 240V AC mains cable via double-pole mains isolator-switch (3 core L.N.E. 1.5mm² SWA)^{1,2}
2. Optional **intercom** cable from motor to dwelling (n1 + 6 core³ 0.22mm² multi-strand shielded cable)
3. Optional **intercom** cable from motor to entry panel (n2 0.22mm² multi-strand shielded cable)
4. Optional but recommended **infrared safety beams** (3 core 0.22mm² multi-stranded)⁴
5. Optional **access control device** (3 core 0.22mm² multi-stranded)
6. Optional **pedestrian key-switch** (2 core 0.22mm² multi-stranded) OR
7. Optional **keypad** (3 core 0.22mm² multi-stranded)⁴
8. Optional **external radio receiver** (3 core 0.22mm² multi-stranded)⁵
9. Optional **pillar lights** (3 core LNE SWA, size according to power requirements)⁶
10. Optional **ground loop for free-exit** (1 core 0.5mm² multi-stranded – silicone coated)⁷

n1 means the number of cores required by an intercom

n2 means the number of cores required by an intercom

1. Possibly increase cable thickness if pillar lights are installed.

2. Type of cable must adhere to municipal bylaws but typically SWA (steel wire armoured) cable is recommended.

The armouring provides excellent screening, which gives better protection against lightning – earth one end of the screening).

3. Allows for all features such as pedestrian opening, status LED, etc., to be operated from the intercom handset inside the dwelling.

Number of cores and type of cable could vary depending on brand of access control system being used.

4. Wireless accessories are available. Please refer to www.censys.com for further information.

5. For optimum range, an external receiver can be mounted on the wall.

6. Requires an external relay

7. Consult manufacturer of loop detector for specific details.

6. Lubrication

The internal gearset of the **D5 SMART** is lubricated by means of an oil bath.



The D5 SMART is supplied with oil in its gearbox and does not require routine oil changes.

7. OPERATOR INSTALLATION

7.1. New Site Installations



When installing the **D5 SMART**, it is important to take note of the information found in Sections 7.1.1. and 7.1.2. when determining the position of the Foundation Plate, and the height of the **D5 SMART** in relation to the gate that is to be automated.

7.1.1. Locating an Initial Reference Point

Firstly, it is necessary to establish a reference point. To do this, manually open and close the gate so that it moves past a stationary point (i.e. a vertical spike), and determine which part of the gate (including its wheels) protrudes the furthest towards where the **D5 SMART** will be installed. Refer to the examples shown below.



Check for wheels, palisade, uprights, etc. that could potentially collide with the pinion.

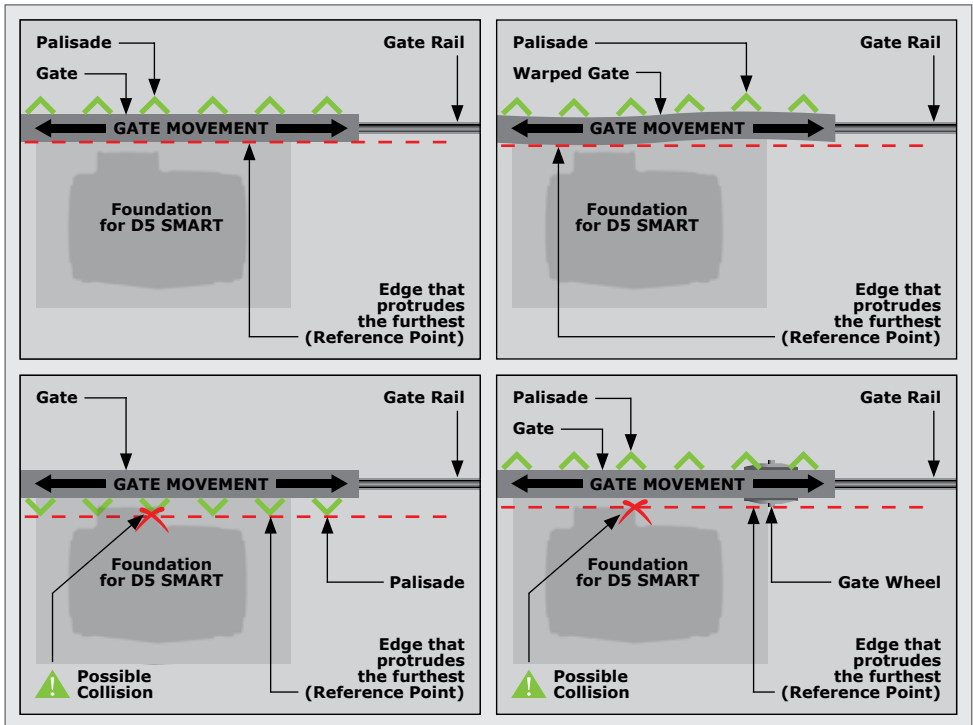

FIGURE 8. FINDING A REFERENCE POINT



Once the point which protrudes the furthest has been found, this will be the reference point to be used when finding the optimum position for the **D5 SMART**.

7.1.2. Minimum Clearances

Below are site plan examples illustrating the minimum clearances required when installing the **D5 SMART**.

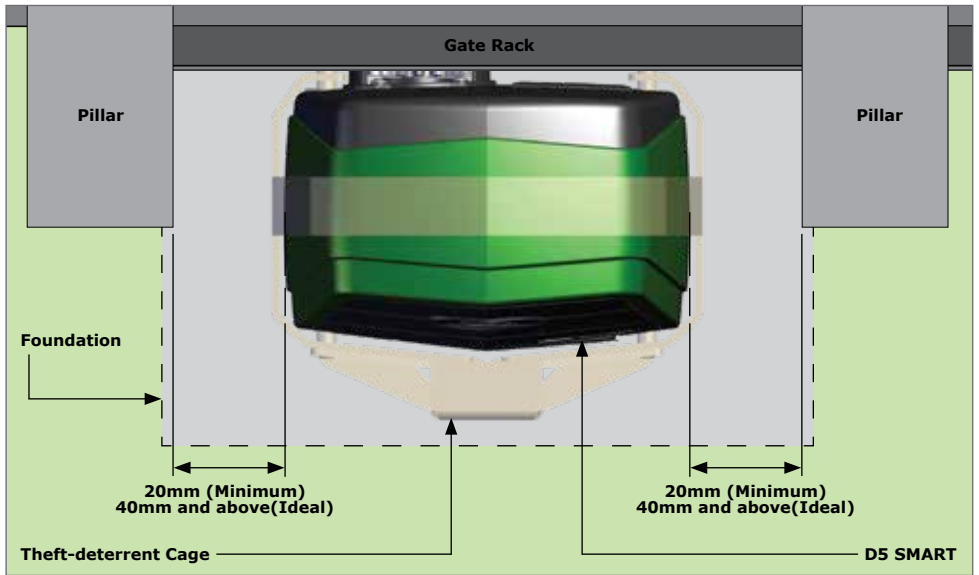

FIGURE 9. MINIMUM CLEARANCES - SIDES

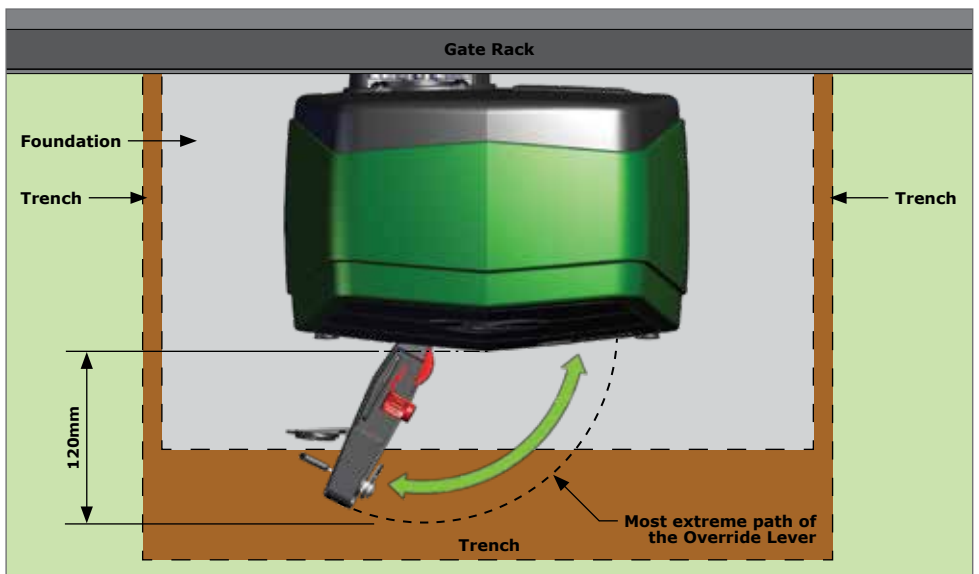

FIGURE 10. MINIMUM CLEARANCES - FRONT

7.1.3. Locating the Operator's Position

To ensure that the operator does not protrude into the driveway, install the base plate at least flush with the driveway entrance.

It is typical to mount the rack above the pinion as shown in Figures 11, 13 and 15 for each type of rack considered. However, in each case, Figures 12, 14 and 16 show the rack mounted underneath.

If there is space to mount the rack underneath without fouling the ground as the gate moves, the following are the pros and cons:

Pros

- The rack is more hidden from view
- It provides a very effective anti-lift bracket
- It ensures that, since the gate beds in, the rack does not drop onto the pinion, loading the operator unnecessarily

Cons

- Rack teeth face up vertically, potentially collecting dirt
- Could require the use of a custom bracket

The measurements given below are based on the three different racks supplied by Centurion Systems (Pty) Ltd and are to be used as guidelines only.

Steel Rack

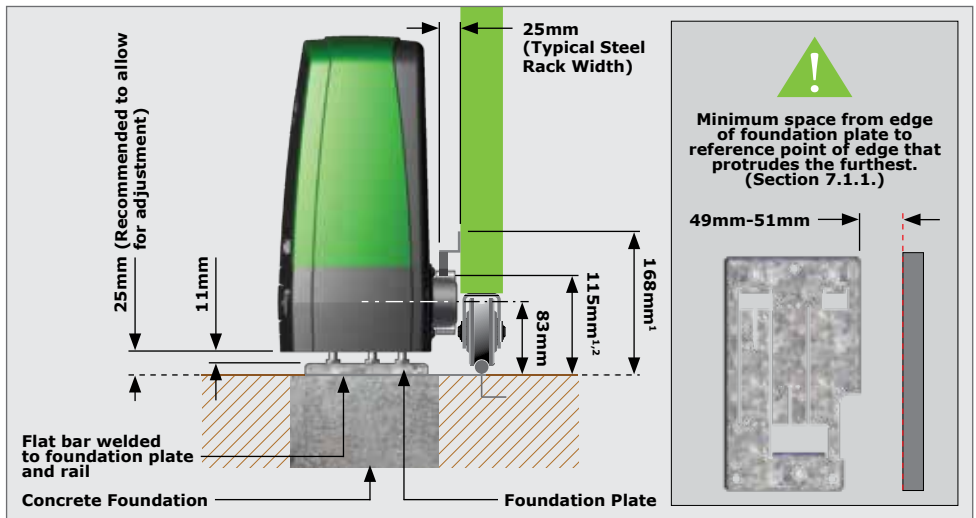

FIGURE 11. STEEL RACK ABOVE PINION

1. Includes 3mm clearance required between rack and pinion
2. Distance between bottom of the Foundation Plate and bottom edge of the Rack Tooth

The principles of installation on a Steel rack is to position in the middle of the output pinion with the operator fully forward on the slots.

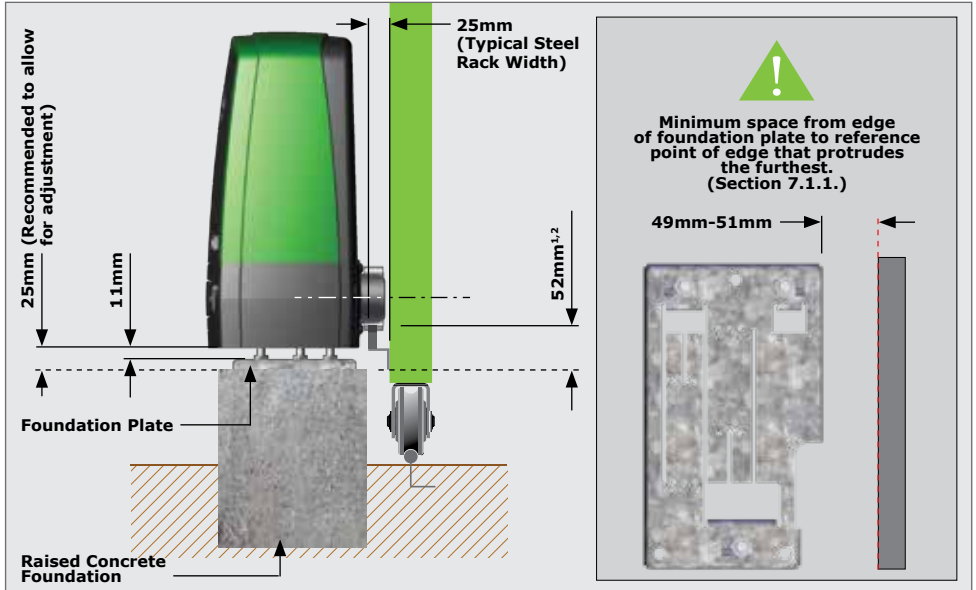

FIGURE 12. STEEL RACK BELOW PINION

1. Includes 3mm clearance required between rack and pinion
2. Distance between bottom of the Foundation Plate and top edge of the Rack Tooth



The principles of installation on a Steel rack is to position in the middle of the output pinion with the operator fully forward on the slots.

RAZ Rack

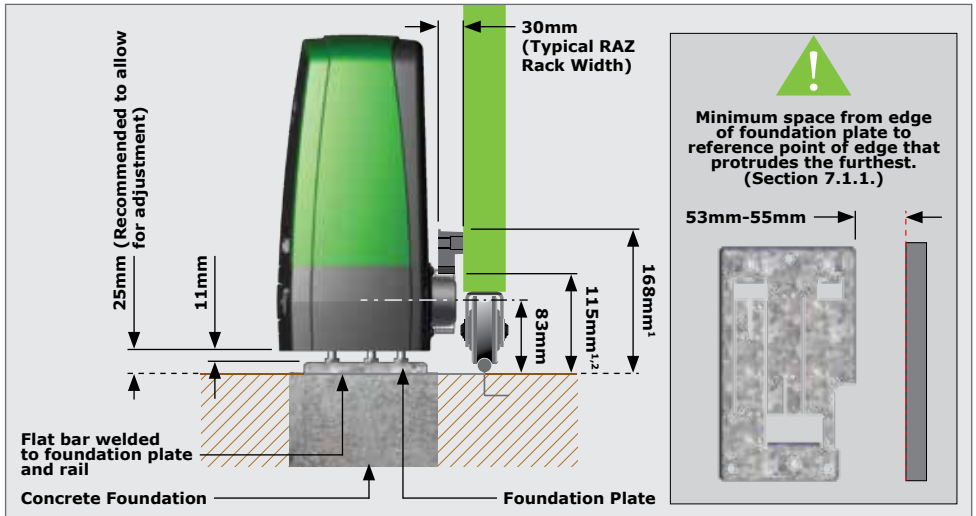

FIGURE 13. RAZ RACK ABOVE PINION

1. Includes 3mm clearance required between rack and pinion
2. Distance between bottom of the Foundation Plate and bottom edge of the Rack Tooth



The principles of installation on a Raz rack is to position in the middle of the output pinion with the operator fully forward on the slots.

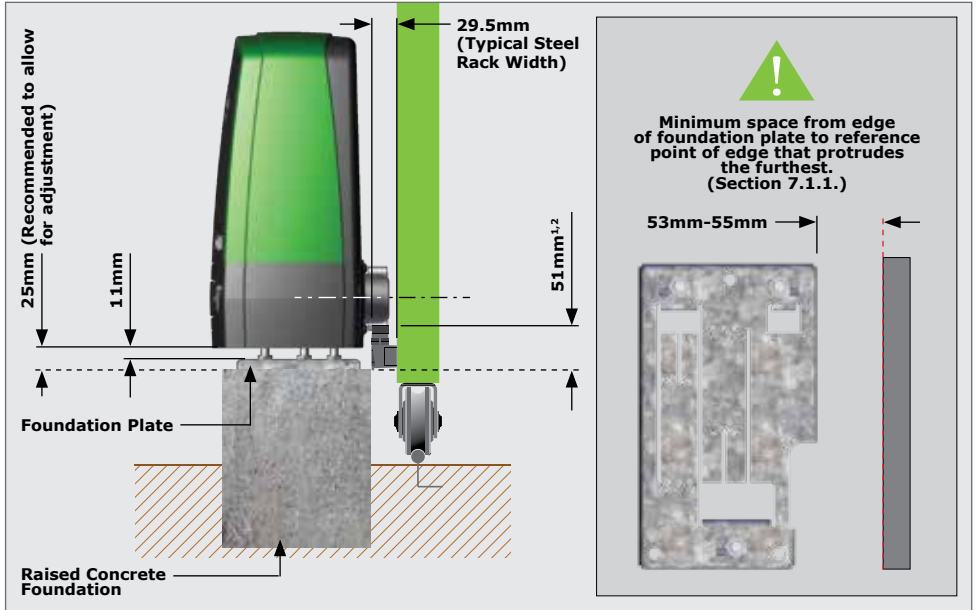

FIGURE 14. RAZ RACK BELOW PINION

1. Includes 3mm clearance required between rack and pinion
2. Distance between bottom of the Foundation Plate and top edge of the Rack Tooth



The principles of installation on a Raz rack is to position in the middle of the output pinion with the operator fully forward on the slots.

Nylon Angle Rack



If using nylon angle rack, please ensure that the weight and pull force of the gate does not exceed the strength limit of the rack.

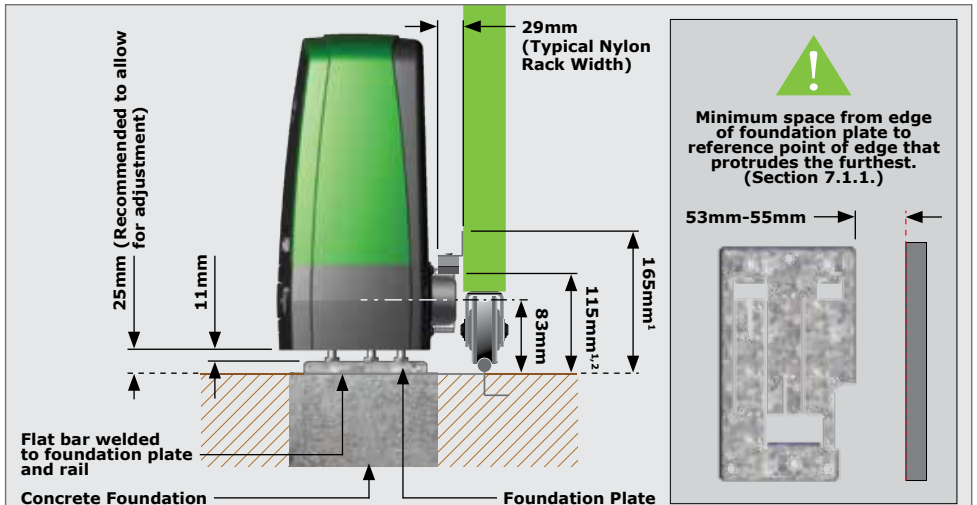

FIGURE 15. NYLON RACK ABOVE PINION

1. Includes 3mm clearance required between rack and pinion
2. Distance between bottom of the Foundation Plate and bottom edge of the Rack Tooth



The principles of installation on a Nylon rack is to position in the middle of the output pinion with the operator fully forward on the slots.

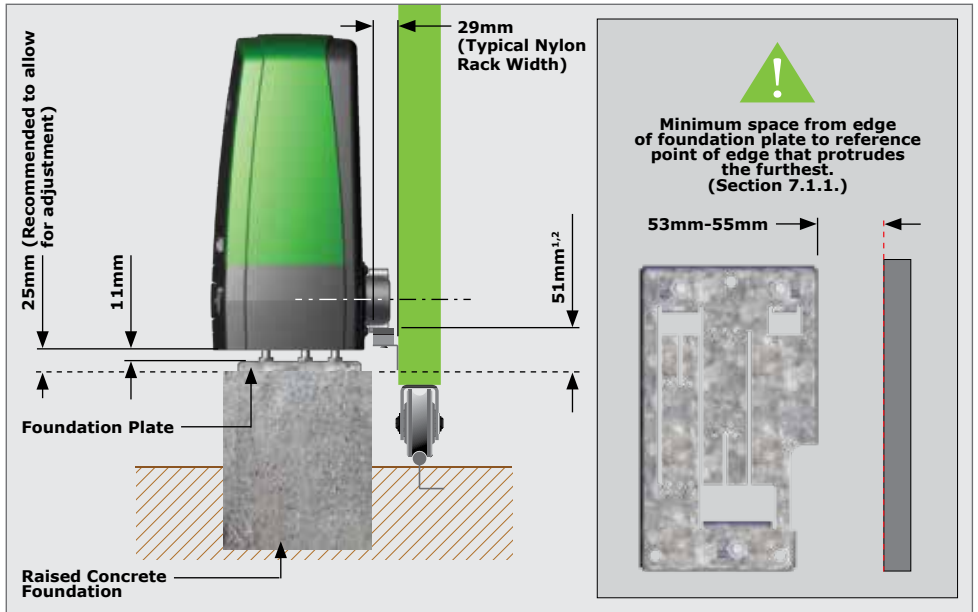

FIGURE 16. NYLON RACK BELOW PINION

1. Includes 3mm clearance required between rack and pinion
2. Distance between bottom of the Foundation Plate and top edge of the Rack Tooth



The principles of installation on a Raz rack is to position in the middle of the output pinion with the operator fully forward on the slots.

7.1.4. Foundation Plate Installation



The foundation plate can either be set into a new concrete foundation, as in Section 7.1.4.1, or bolted down onto an existing concrete plinth as in Section 7.1.4.2.

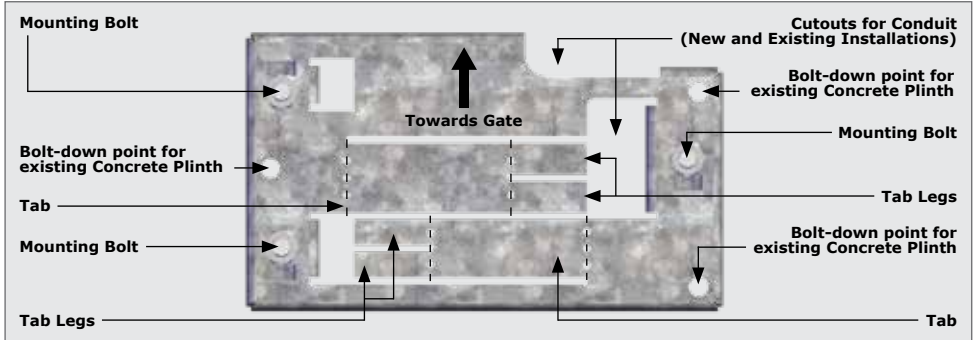

FIGURE 17. FOUNDATION PLATE ASSEMBLY - TOP VIEW

7.1.4.1. New Concrete Foundation



Check that the M10 half-nuts are tightened to 20Nm on the mounting bolts.

Using a pair of pliers, gently bend the two tabs of the foundation plate down to a 90° angle as shown in Figure 18.



Be careful not to deform the Foundation Plate while bending the tabs.

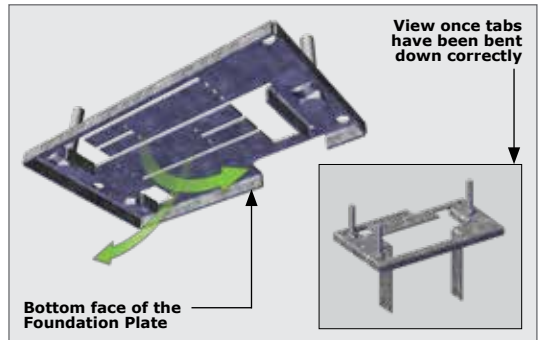

FIGURE 18

Again, using a pair of pliers, gently bend the two legs on each tab to an angle of 90° in opposite directions as shown in Figure 19.



Be careful not to deform the Foundation Plate while bending the tabs.

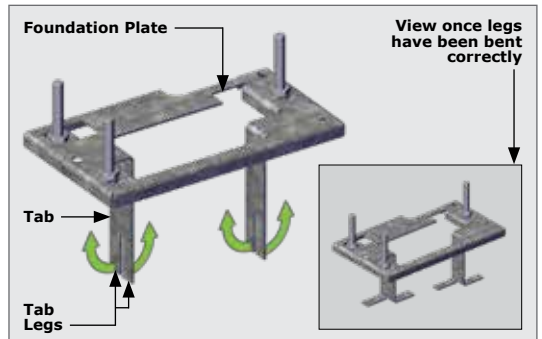

FIGURE 19



Lay the cabling conduit so that it routes the cables to the back of the Foundation Plate. Ensure that 30mm of conduit protrudes above the concrete.

Using medium-strength concrete (25MPa), cast the plinth according to the dimensions as shown in Figure 20.

When using a concrete foundation, it is recommended that the foundation plate is welded to the rail/track of the gate using a short length of flat bar, as shown in Figure 21. This makes it possible to complete the whole mechanical and electrical installation without having to wait for the concrete to set. After completing the installation, the concrete can be poured and the operator left in manual mode until the concrete has set. Do not operate the motor until concrete has completely set.



7.1.4.2. Existing Concrete Plinth

If bolting onto an existing concrete plinth, place the foundation plate down in the correct position and use the plate as a template for marking the rawl bolt holes.



Check that the M10 half-nuts are tightened to 20Nm on the mounting bolts.



Rerouting of existing cables may be necessary.

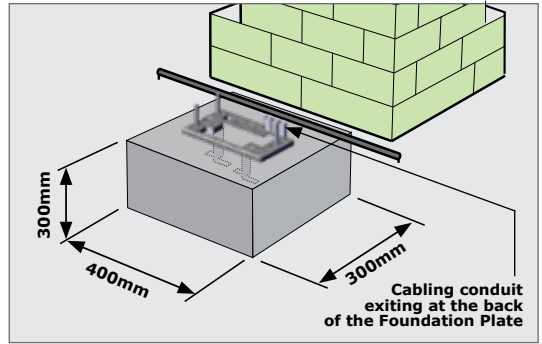

FIGURE 20

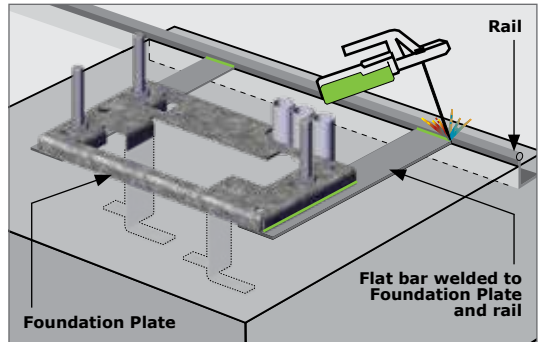

FIGURE 21

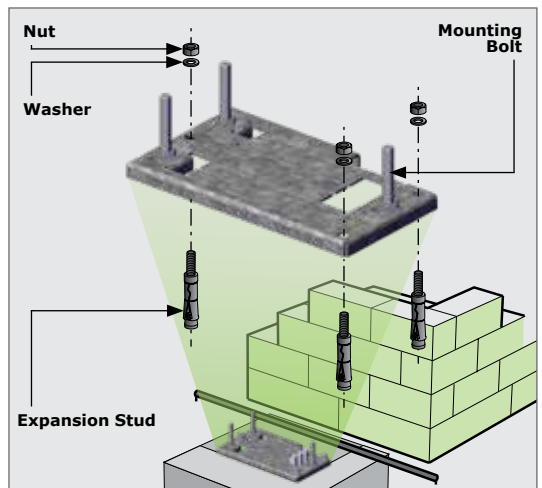

FIGURE 22

7.2. Retro-fit Installations (Existing Sites)

The **D5 SMART** has been designed to retro-fit into most existing D3, D5, or D5-Evo installations, with the following provisions;

- If the unit is installed with the gate in the closed position and the unit on the left-hand side (from the inside of the property), the rack should extend at least 75mm past the centre line of the existing pinion
- If the existing unit is mounted with the maximum clearance to the foundation plate, the new unit will require that the rack be re-adjusted to obtain the correct mesh between the rack and pinion, as the existing bolts will be too short

If the existing foundation plate is in a good condition, it is not necessary to replace it with the **D5 SMART** Foundation Plate. However, if the existing foundation plate is corroded or needs to be replaced for whatever reason, the **D5 SMART** foundation plate can accommodate the existing footprint without the need to re-route cable conduits.

7.2.1. Retro-fitting if the Existing Foundation Plate is Unusable

Thoroughly inspect the existing foundation plate to determine whether or not it is fit to be reused. A foundation plate that is corroded or otherwise damaged should be discarded and replaced with the **D5 SMART** foundation plate.

Follow the procedure found under Section 7.1.4.2. - "Existing Concrete Plinth".



There is an allocated slot for existing conduit from previous D3, D5, and D5-Evo installations as shown in Figure 23.

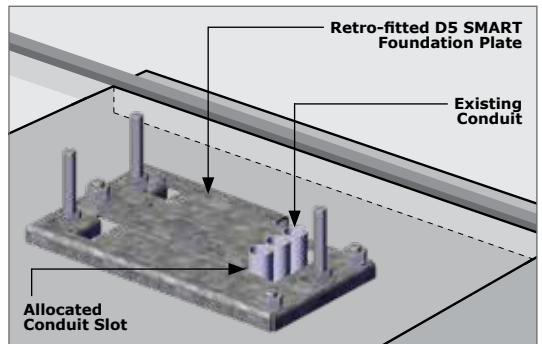

FIGURE 23

7.3. Conduit and Cable Length

Route the cables as determined in Section 5.5 - "Cabling Requirements".

Make sure that the conduits protrude above the concrete foundation. The mains cables should protrude 360mm above the concrete foundation, and all signal cables (i.e. beams, etc.) 550mm above the concrete foundation, as shown in Figure 24.

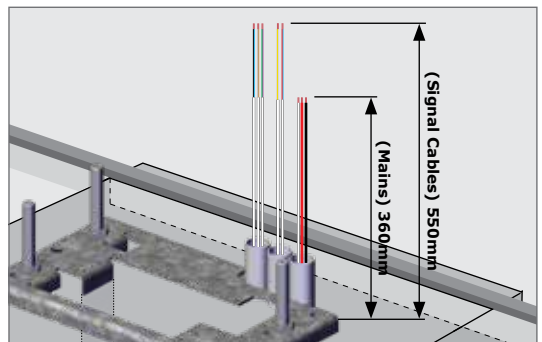

FIGURE 24

7.4. Preparing the D5 SMART for Installation

Open the Camlock Cover, and insert the Operator Key into the Camlock. Unlock it by turning the key anti-clockwise.



There is no need to open the Release Handle to remove the cover of the **D5 SMART**.

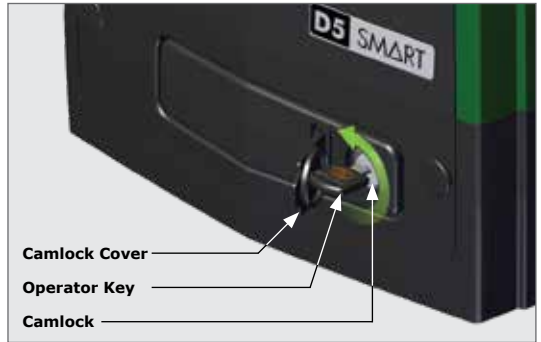

FIGURE 25

Remove the cover of the **D5 SMART** to expose the internal components, and place it one side in a safe location.

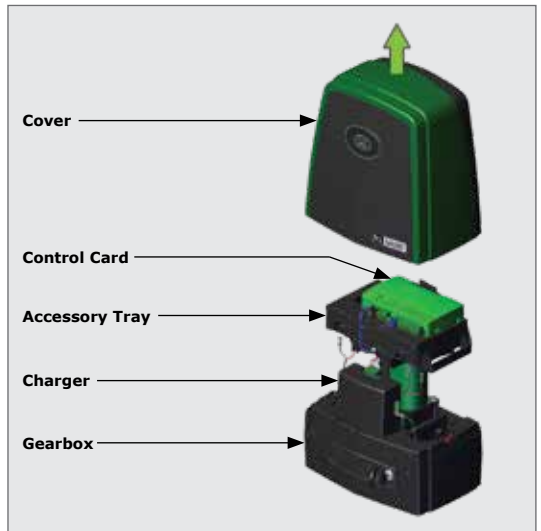

FIGURE 26

7.4.1. Removing the Charger

Disconnect the Charger from the **D5 SMART** Control Card at either Point "A" or Point "B".



If the disconnection is made at Point "A", note that there are two connector blocks that need to be disconnected from the Control Card.

Disconnect the Earth Harness from the Charger at Point "C", and store it in a safe place.

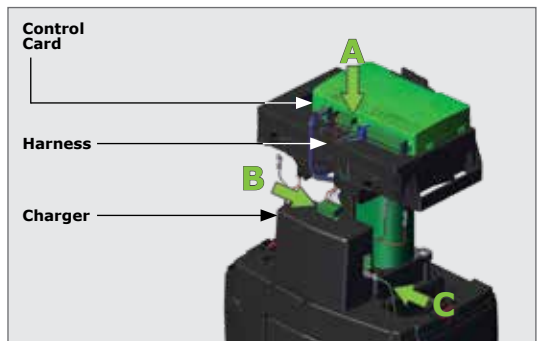

FIGURE 27

Remove the Charger from the lower battery tray by gently pushing the Charger slightly down whilst pulling it towards the front of the **D5 SMART**. It should slide forward and off with ease.

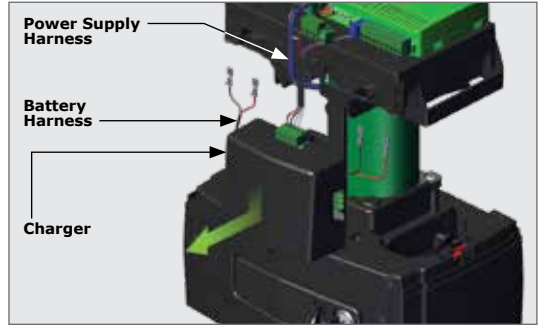

FIGURE 28

7.4.2. Removing the Lower Battery Tray

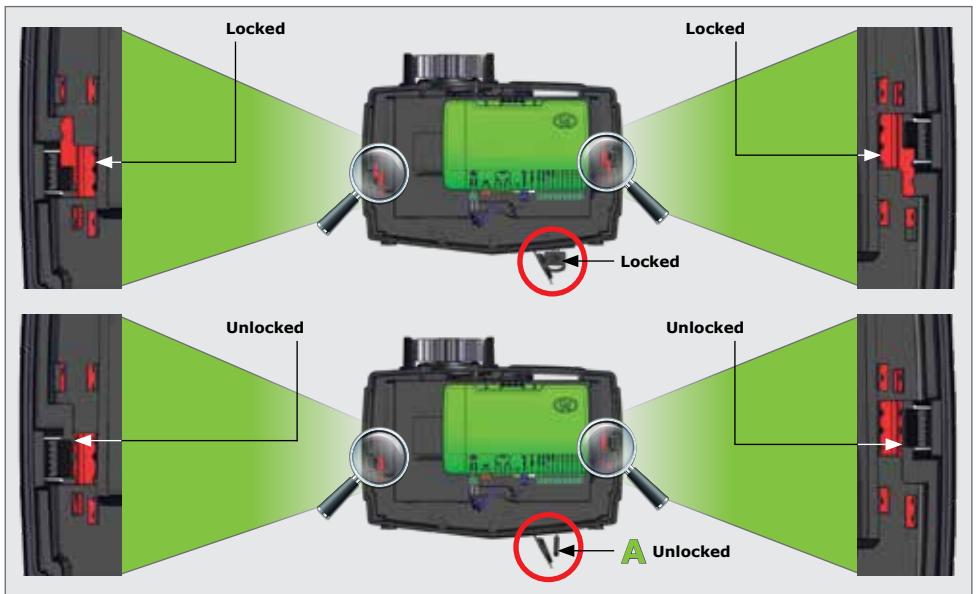

FIGURE 29

To remove the Lower Battery Tray, firstly ensure that the Camlock is in the "unlocked" position (Figure 29 marked as "A"). Open the release handle until the Camlock Cam is visible.

Using a flat screwdriver, lever the left and right Tabs inward, lift the Lower Battery Tray up, and then out towards the front of the **D5 SMART**.

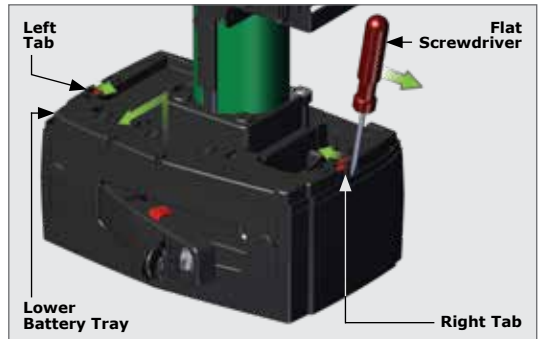

FIGURE 30

7.4.3. Removing the Control Card

Disconnect the Motor Wires at Point "D" and the Override Sensor Harness at Point "E" from the Control Card as Shown in Figure 31.

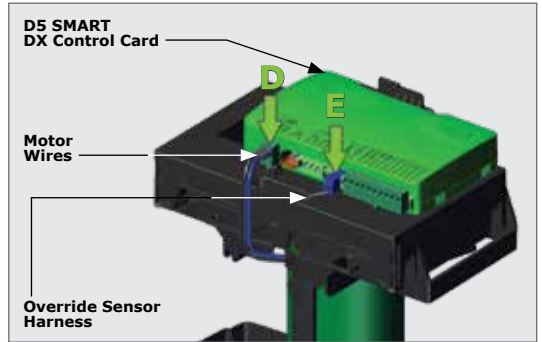

FIGURE 31

Remove the Control Card by pushing the right tab behind the Control Card backwards.

This will allow the Control Card to hinge forward.

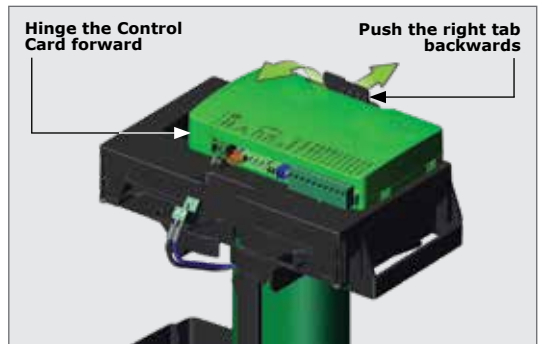

FIGURE 32

Lift the Control Card upwards and away from the **D5 SMART**, which will unhinge it from the hinge tabs found on the sides of the Control Card.



Take care not to snag the remaining harnesses in the harness retainers when removing the Control Card from the platform.

Store the Control Card in a safe place.

The **D5 SMART** is now ready to be mounted onto the foundation plate.

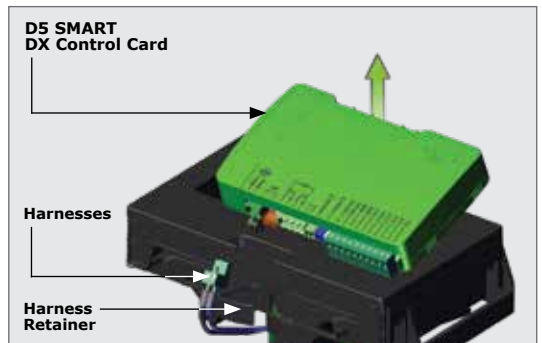

FIGURE 33

7.5. Mounting the Gearbox

For a new site installation, place a Half-nut and a Bottom Height Adjuster onto each Mounting Bolt as shown in Figure 34.



Note the orientation of the Bottom Height Adjusters.

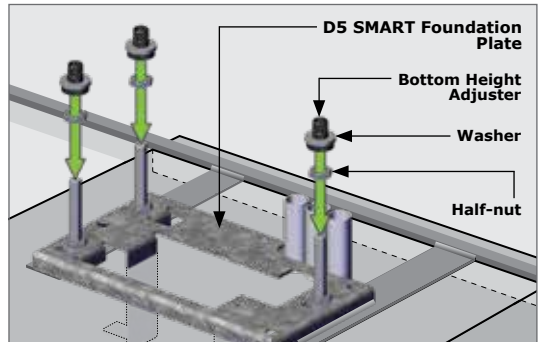

FIGURE 34

Adjust the Half-nuts to be 12mm clear from the Foundation Plate.

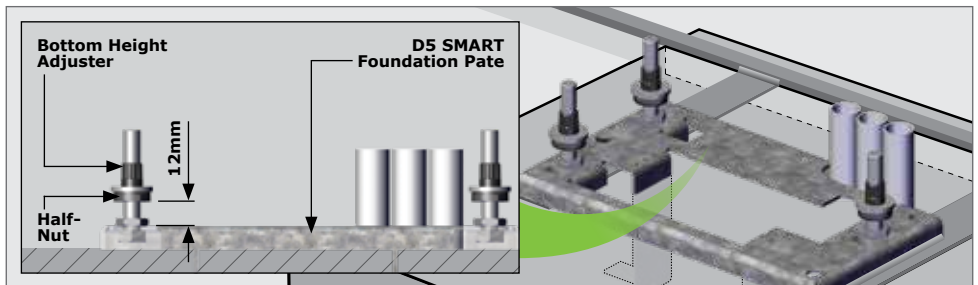

FIGURE 35

For a retro-fit installation, remove the original washers and height adjustment nuts from the existing foundation plate and then place a Half-nut and a Bottom Height Adjuster onto each existing Mounting Bolt, as shown in Figure 36.



Note the orientation of the Bottom Height Adjusters.

If the existing unit was mounted with the maximum clearance to the foundation plate, the new unit will require that the rack be re-adjusted to obtain the correct mesh between the rack and pinion.

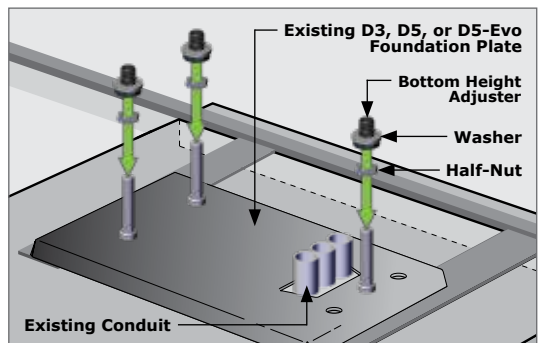

FIGURE 36

Removing the Cable Shield

The Cable Shield needs to be removed before mounting the **D5 SMART** onto its Foundation Plate. This is done by levering the bottom end of the cable shield away from the motor until it unclips from the gearbox, and then slide it up.

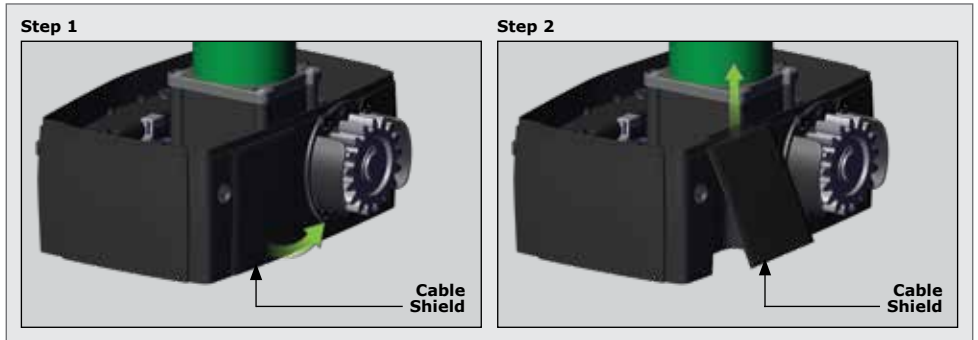

FIGURE 37

Once the Cable Shield has been removed, place the **D5 SMART** into position over the three Mounting Bolts, aligning them with the three slots at the bottom of the gearbox and rest the **D5 SMART** onto the Bottom Height Adjusters.

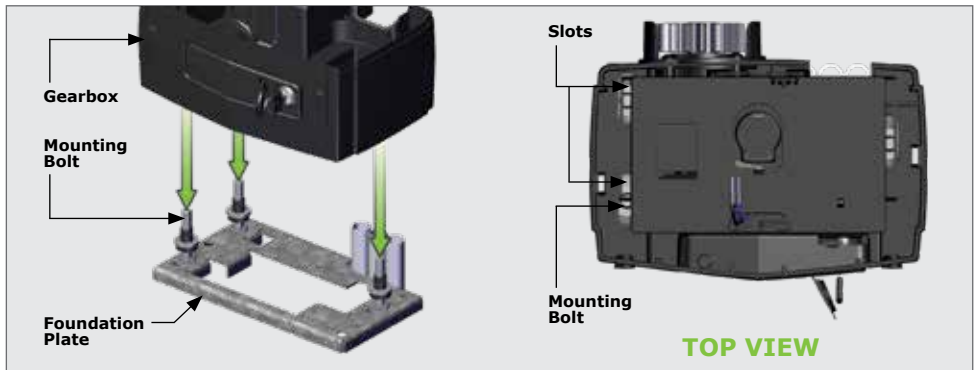

FIGURE 38

Once the Gearbox is resting on top of the Bottom Height Adjusters, slide the **D5 SMART** as far as possible towards the gate to allow for later adjustment.

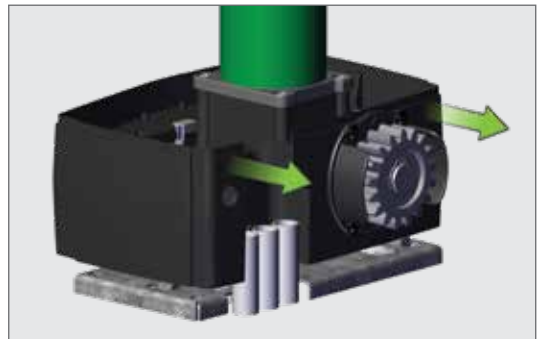

FIGURE 39

7.6. Routing the Cables

Route cables as determined in Section 5.5 - "Cabling Requirements".

POINT A is the entry point for cables with the conduit installed at the back of the unit for new installations as shown in Figure 41.

Although POINT B is the entry point for cables with the conduit from existing D3, D5 and D5-Evo installations, it is recommended to route the cable under the gearbox and out the back through Point A as shown in Figure 42.

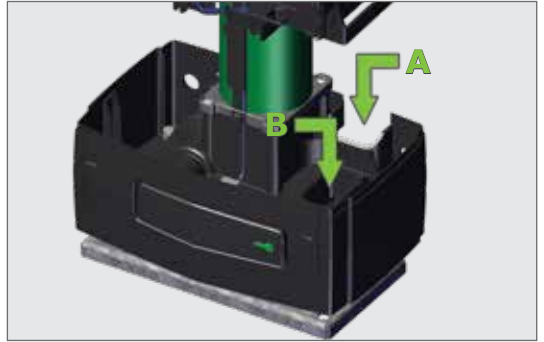

FIGURE 40

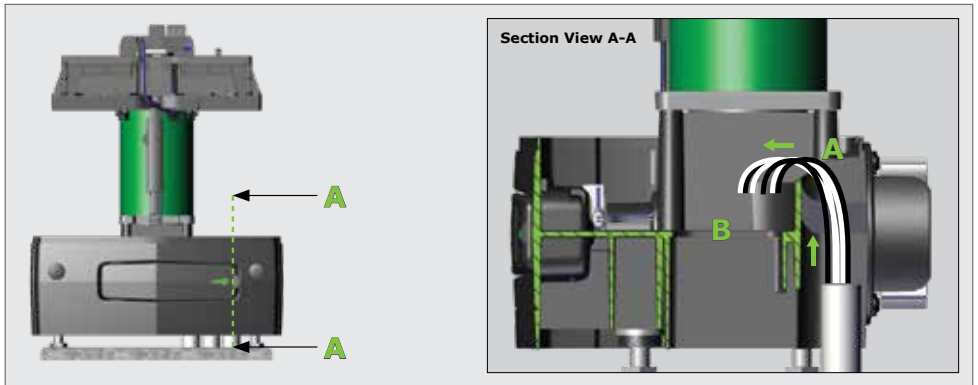

FIGURE 41. CABLE ROUTING FOR NEW INSTALLATIONS

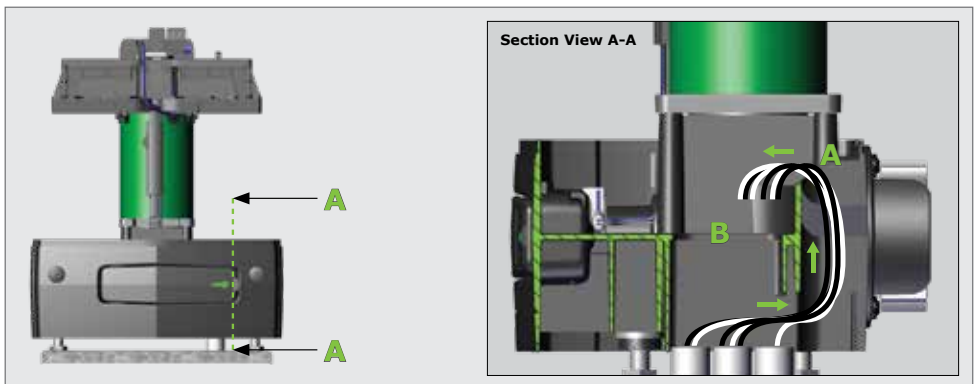

FIGURE 42. CABLE ROUTING FOR RETRO-FITS WITH LONGER CABLES



The method shown in Figure 43 above, is recommended for retro-fit installations, as it is easier to remove the motor should it be necessary to do so at a later stage. However, cable lengthening may be required.



Should the existing cables for a retro-fit installation be too short to route through "Point A" as shown in Figure 43 on the previous page, they can be routed directly through "Point B" to accommodate the shorter length. Note that routing the cables through "Point B" as shown in Figure 43, may make it more challenging to remove the **D5 SMART** for whatever reason at a later stage.

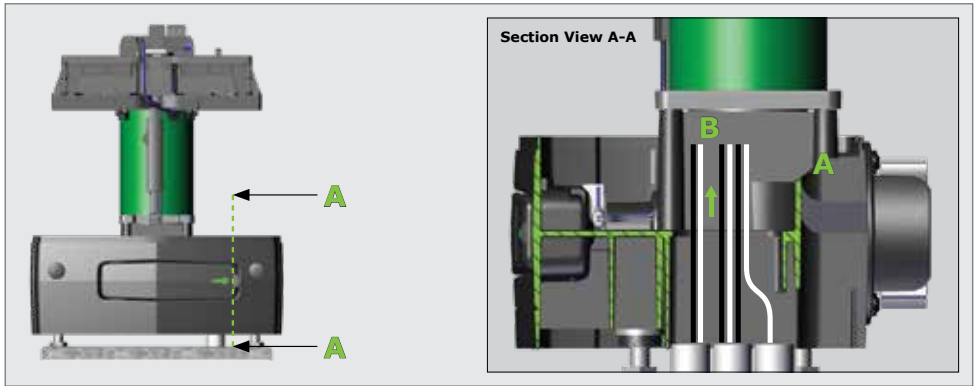

FIGURE 43. CABLE ROUTING FOR RETRO-FITS WITH SHORTER CABLES

Replacing the Cable Shield onto the Gearbox

Tilt the top of the Cable Shield towards the Gearbox, and slide it down so that the top of the Cable Shield is flush with the top edge of the Gearbox.



FIGURE 44

From the other side of the gate, firmly push the bottom sides of the Cable Shield inward, towards the gearbox.

Two clicks will be heard (one from each side of the Cable Shield) if the Cable Shield has engaged with the gearbox correctly.

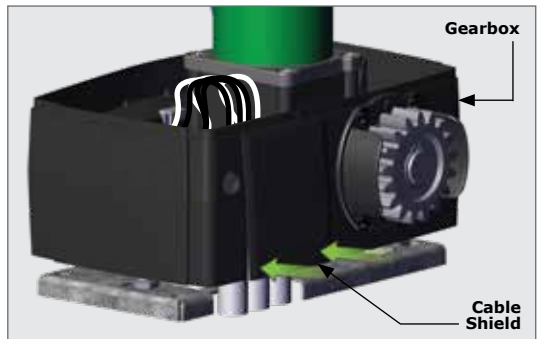

FIGURE 45

7.7. Manual Override



Before mounting the rack to the gate, ensure that the D5 SMART is in Manual Override. Follow the instructions below.

To disengage (manual override) the motor, ensure that the Camlock is in the "unlocked" position, and pull the Release Handle as far left as it will go. The Motor will then be placed in a temporary state of disengagement.

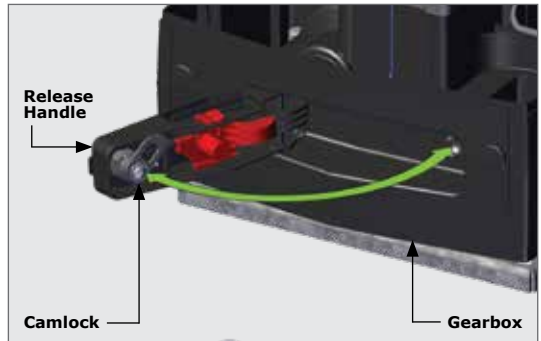

FIGURE 46

Manual Override Latching

In the event of a power failure, it may be required to lock the cover in place whilst "latching" the manual release (i.e. manual release permanently enabled).

This helps prevent theft of the unit, or its components, and provides full protection from the elements.

With the release handle in the open position, slide the Override Cam located on the inside of the handle towards the gearbox, and a "click" can be heard once it has located correctly. Return the handle to the closed, or locked, position. This allows continued manual operation of the gate while ensuring that the cover remains securely locked in place. See Figure 47.

To re-engage the **D5 SMART** (i.e. take the operator out of latched Manual Override), push the Release Handle Override Cam to the left and then slide it towards the Camlock. See Figure 489.

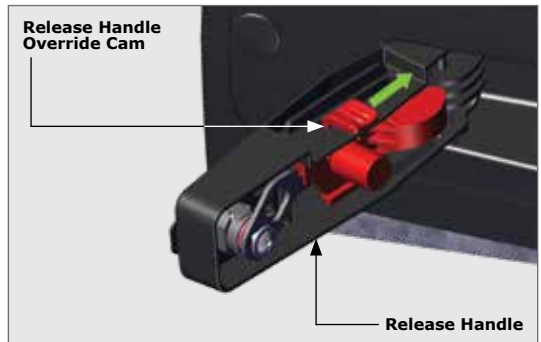

FIGURE 47

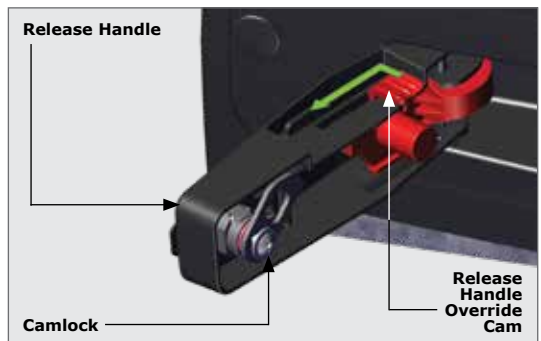

FIGURE 48

7.8. Height Adjustment

The **D5 SMART**'s unique Height Adjustment System adjusts from the top of the gearbox. This adds further security to the system, as it is not possible to access the lock nuts from the outside of the gearbox.

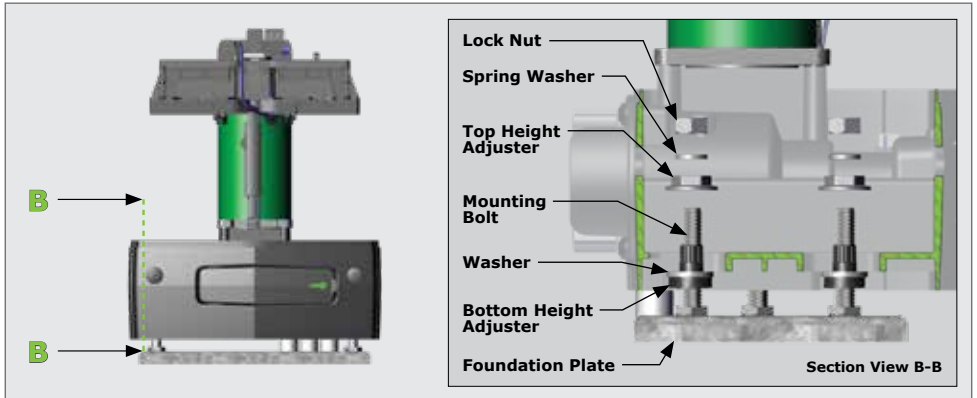

FIGURE 49



Only add the Spring Washers and Lock Nuts once the Rack has been installed and the operator height is correct. See Section 7.9.2. - "Finalising the Height Adjustment".

Place a Top Height Adjuster onto each Mounting Bolt so that it engages with the teeth on the Bottom Height Adjuster.



Note the orientation of the Top Height Adjuster as shown in Figure 49 and 50.

Using a ratchet and a 19mm socket, turn the Top Height Adjuster anti-clockwise to lift the Operator, or turn it clockwise, to lower the Operator.

Using a spirit level, ensure that the Operator is level. If not, use the Height Adjusters to level the Operator.

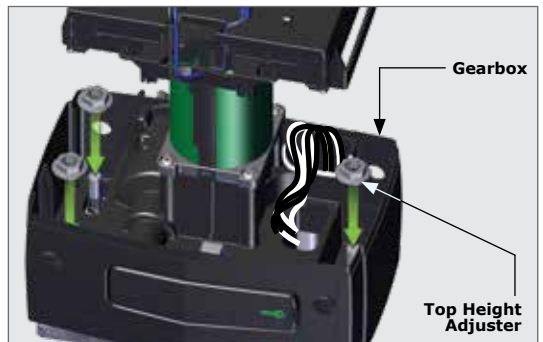

FIGURE 50

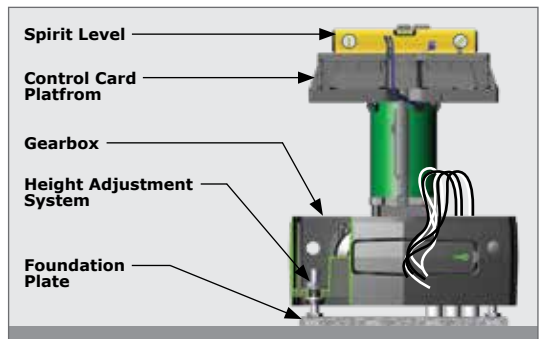

FIGURE 51

7.9. Mounting the Rack



The rack must be securely mounted to the side of the gate. It must be parallel with the gate rail and there must be a 2-3mm gap between the rack teeth and the teeth of the pinion.

The **D5 SMART** is supplied with the Pinion Spyder, which greatly enhances the accuracy and speed of achieving the 2-3mm gap between the Pinion and the gate's rack.

Fit the Pinion Spyder onto the Pinion of the **D5 SMART** by aligning its teeth with the gaps between the teeth of the **D5 SMART**'s Pinion.

Ensure that the **D5 SMART** Gearbox is in Manual Override. Refer back to Section 7.7 - "Manual Override".

Start with the gate either fully open or fully closed.

Slide the **D5 SMART** back towards the gate to where the Pinion will sit just under where the rack will be fixed to the gate.

Rest the rack directly onto the Pinion Spyder while welding / bolting the rack into position.

Level the other end and fix that end to the side of the gate, as shown in Figure 54.

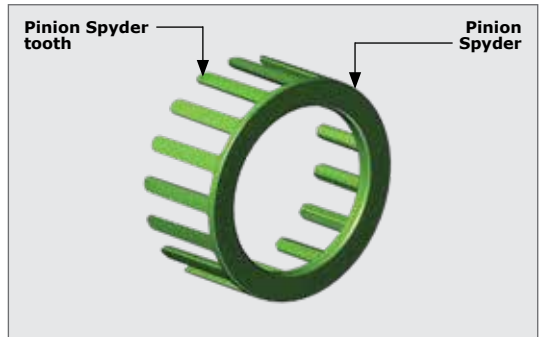

FIGURE 52

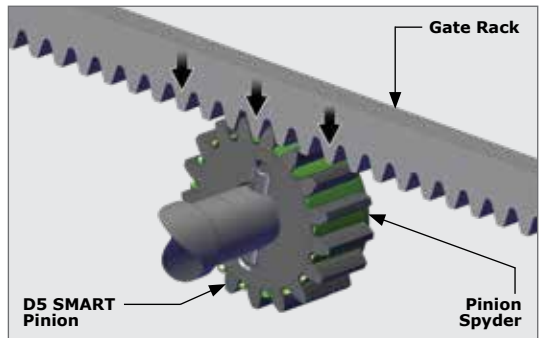

FIGURE 53

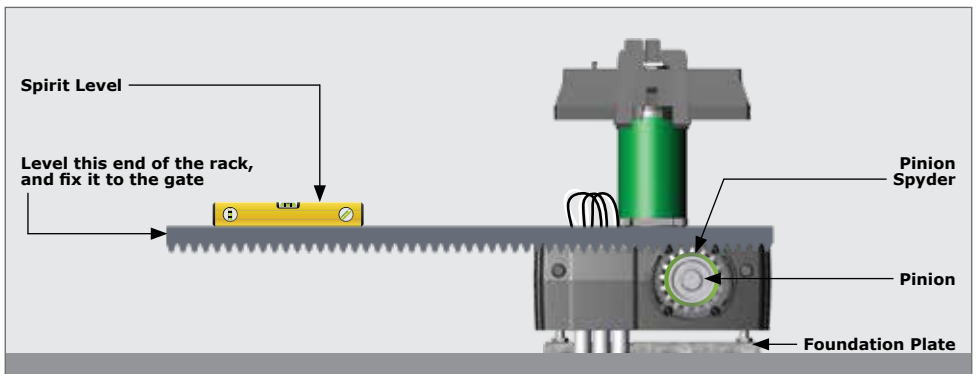



FIGURE 54. THE RACK AND OPERATOR FROM THE GATE'S PERSPECTIVE



Refer to the instructions on how to fix the different types of rack to a gate in Section 7.9.1. - "Fitting Different Types of Rack to the Gate".

Slide the gate halfway along the first section and level the unsecured end, ensuring that the rack is resting on the Pinion Spyder, not pressing down. Continue this way to fix all sections.

 Before fully fixing each section of rack, slide the gate backwards and forwards along the section, checking that the rack is only resting on the Pinion Spyder, and not pressing down onto it.

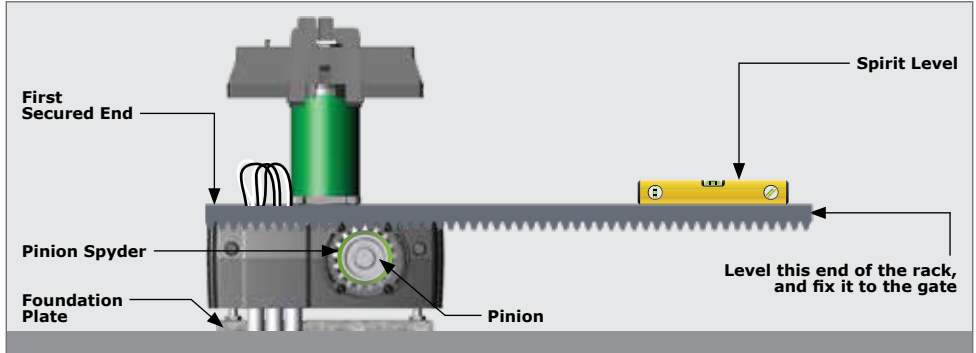

FIGURE 55. THE RACK AND OPERATOR FROM THE GATE'S PERSPECTIVE

7.9.1. Fitting Different Types of Rack to the Gate

Steel Rack

Fix the Steel Rack with the steel angle brackets provided. The brackets must be spaced no more than 300mm apart.

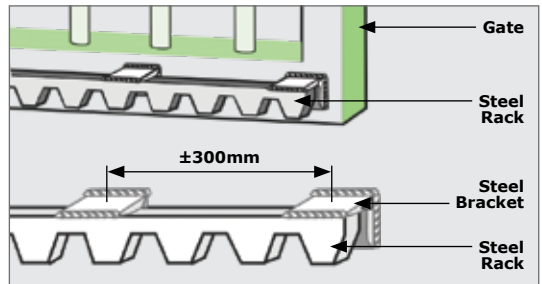



FIGURE 56

When joining different lengths of Steel Rack, a simple way of ensuring that the correct pitch spacing is achieved, is to clamp a small off-cut between the two pieces.

 Do not weld the off-cut to the gate or the join.

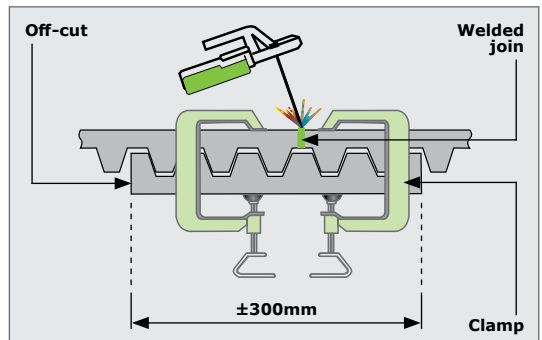

FIGURE 57

RAZ Rack

Fix the RAZ Rack to the side of the gate using the TEK screws provided. Use the vertical slots in order to allow for adjustment.

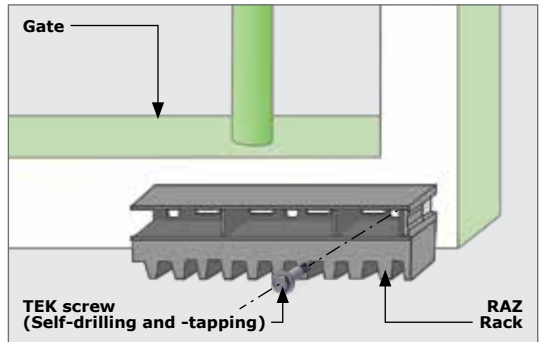

FIGURE 58

When fitting RAZ Rack, it is easier to start on the right and work towards the left.

The RAZ Rack sections simply interlock with each other.

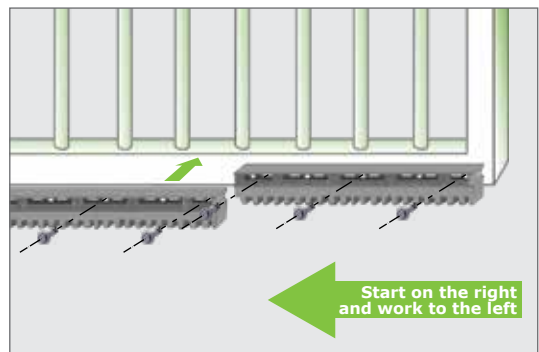

FIGURE 59

Fit an additional fixing screw through the horizontal slots to secure the rack to the gate directly above the Pinion when the gate is in the closed, pedestrian and open positions as shown in Figure 60.



Fit an addition screw through the horizontal slots at the ends of each section of Rack to further strengthen the joins.

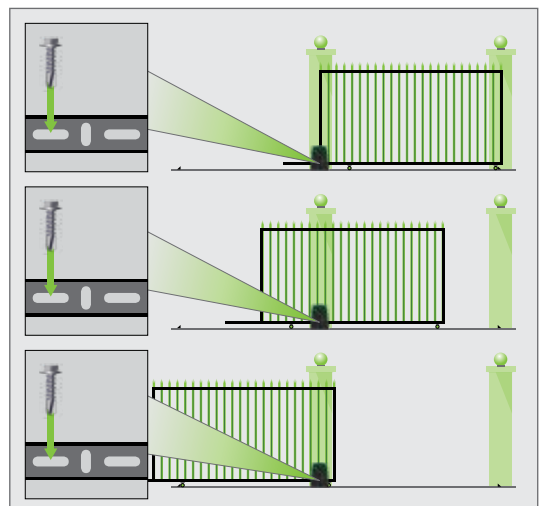

FIGURE 60

Nylon Angle Rack

Fix the Rack to the side of the gate using TEK screws.



Ensure that all the mounting holes provided in the angle section are used.

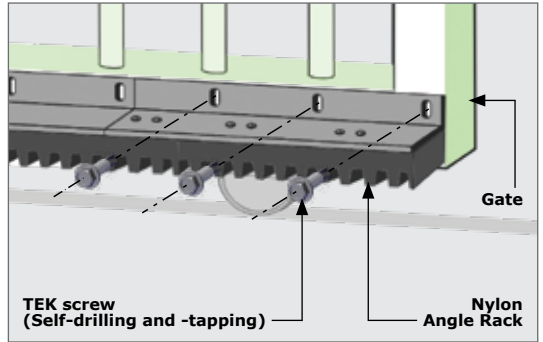

FIGURE 61

When joining two lengths together, simply butt each section firmly together to ensure that the correct pitch is achieved.

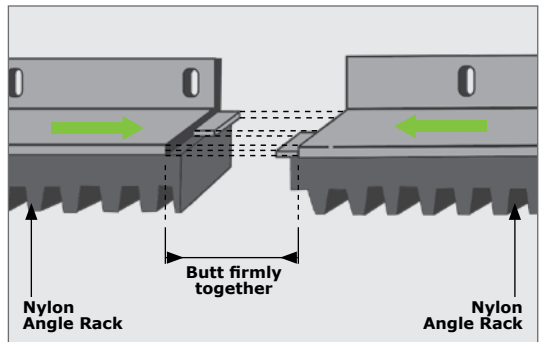

FIGURE 62

7.9.2. Finalising the Height Adjustment

Once the rack has been fixed to the entire length of the gate, use a screwdriver to carefully remove the Pinion Spyder from the Pinion of the **D5 SMART**.

Slide the **D5 SMART** away from the gate so that the rack is centred above the Pinion.

Final adjustment to the position of the gearbox should be done at this point.

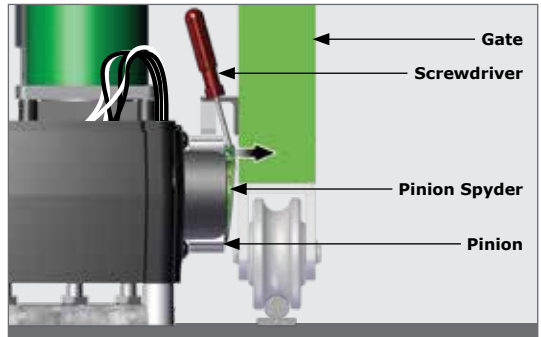

FIGURE 63

7.9.2.1. Placing and Routing the Earth Harness

Place the Ring Lug-end of the Earth Harness onto the mounting bolt on the right-hand side of the Gearbox.

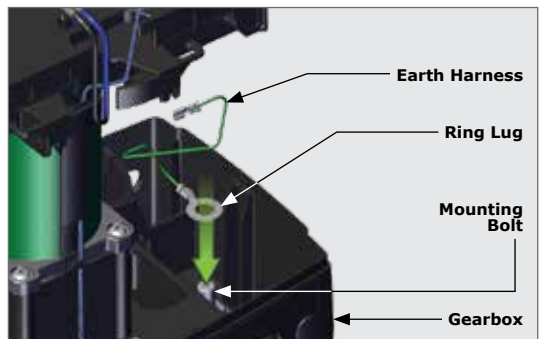

FIGURE 64

To ensure that the Earth Harness is able to reach the Charger once connected to the mounting bolt, it is recommended that it is positioned at the angle depicted by the middle line, but not at an angle exceeding the lines at either side of it as the Earth Harness will not be able to reach the Charger.

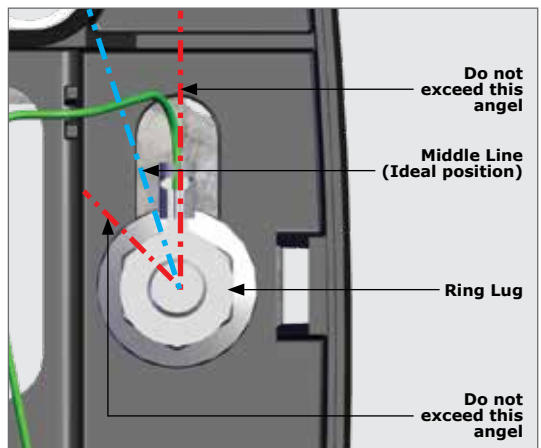

FIGURE 65

Route the Earth Harness up to the left and place it into the Cable Management Clip as shown in Figure 66.



The Earth Harness will need to be routed under the battery at a later stage.

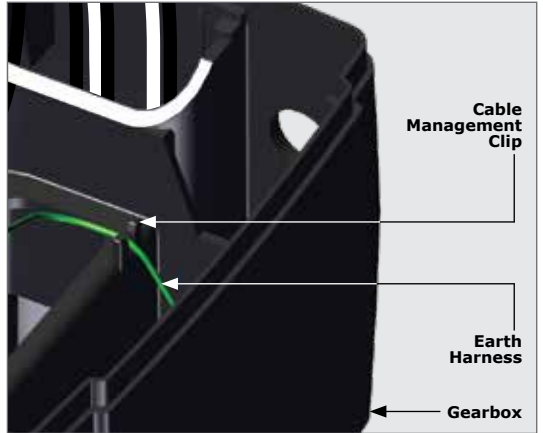

FIGURE 66

7.9.2.2. Placing the Spring Washers and Lock Nuts



Only add the Spring Washers and Lock Nuts once the Rack has been installed and the operator height is correct.

Place one Spring Washer and one Lock Nut onto each of the Mounting Bolts. Tighten all of the Lock Nuts with a 17mm socket to secure the Earth Harness and the height of the **D5 SMART** firmly in position.

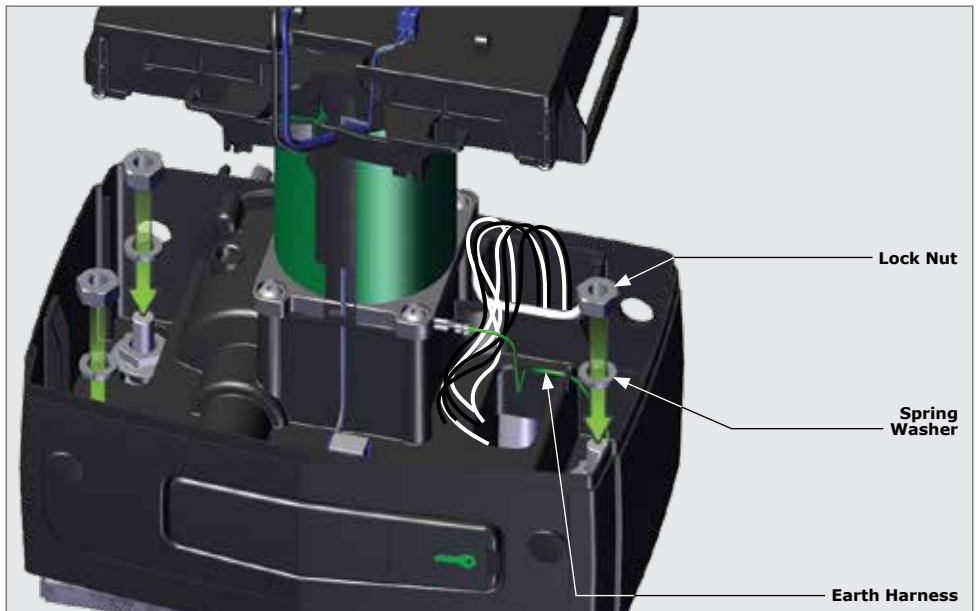

FIGURE 67

7.10. Re-assembling the D5 SMART

7.10.1. Override Sensor



If the Override Sensor has previously been removed, take note of how it is placed back into position correctly, before continuing with the installation.

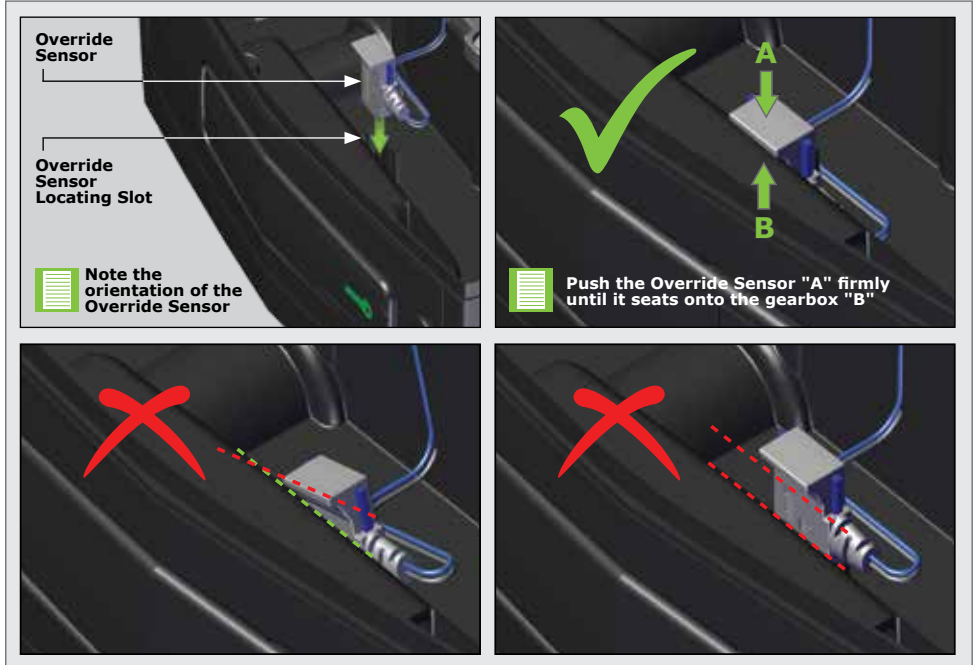

FIGURE 68. OVERRIDE SENSOR

7.10.2. Routing the Override Sensor Harness



It is important to ensure that the harness for the Override Sensor is routed through the correct location when inserting the Lower Battery Tray back into position.

The Override Sensor harness is routed directly in front of the electric motor.

There is a groove located in the middle of the Lower Battery Tray, on the motor's side. The harness needs to be routed between the electric motor and the Lower Battery Tray here as the Lower Battery Tray is placed back into position.

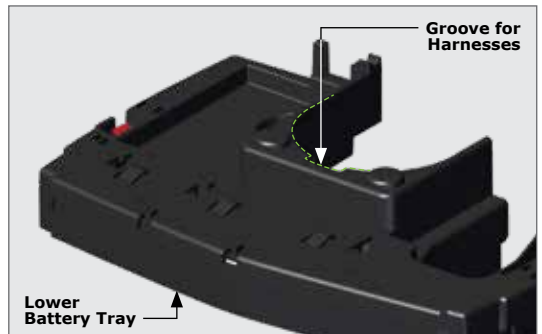

FIGURE 69

7.10.3. Placing the Lower Battery Tray and Charger back into Position

Ensure that the Camlock is in the "unlocked" position and that the Release Handle is partially open.

Place the Lower Battery Tray into position. Whilst doing this, route the cabling and harnesses through. A click from both sides will be heard if the tray is fitted correctly.

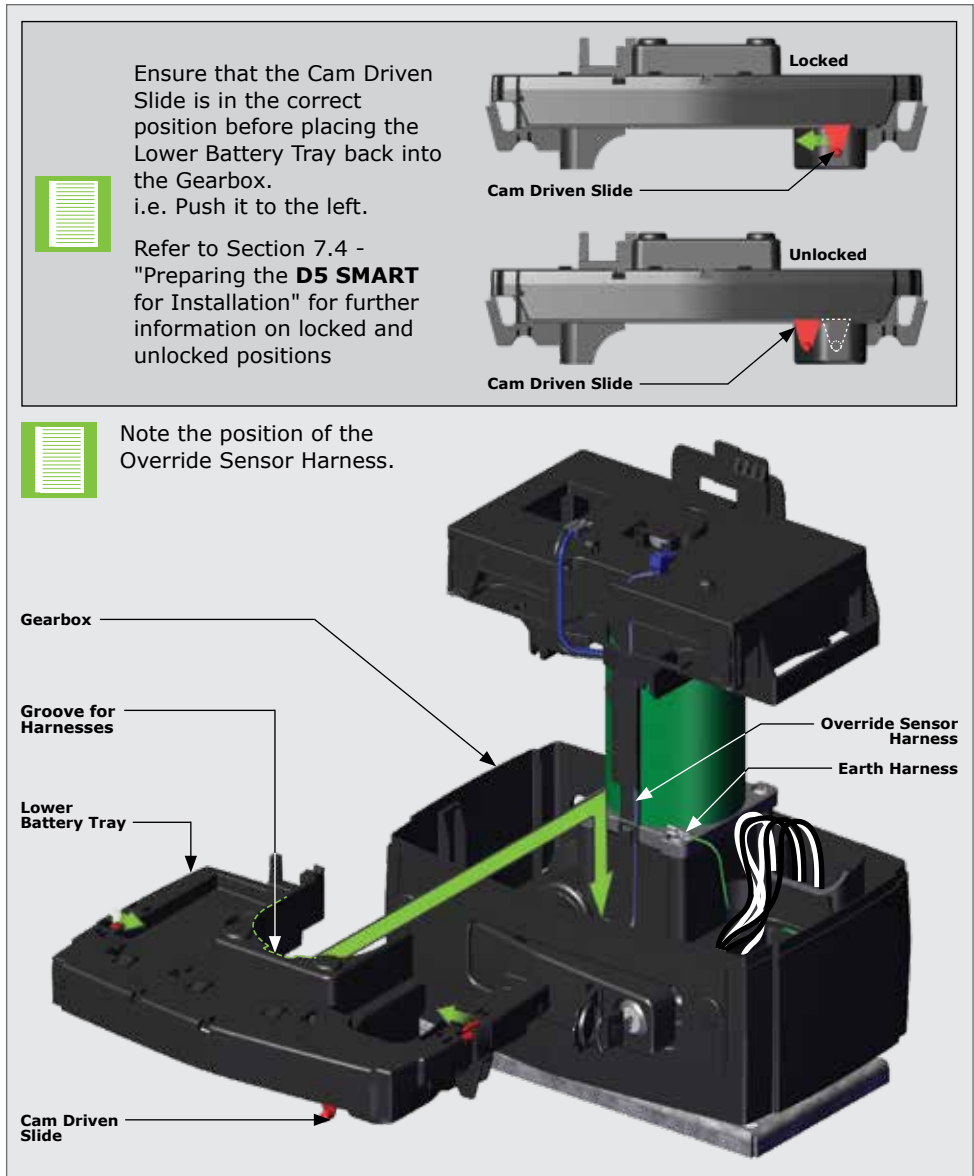

FIGURE 70. LOWER BATTERY TRAY PLACEMENT

Place the Charger back into position by aligning the three feet at the bottom of the Charger with the three slots found on top of the Lower Battery Tray.

Place the studs of the Charger into the three holes on the Lower Battery Tray. Firmly press the Charger down, and push it toward the Electric Motor, sliding it along the slots.

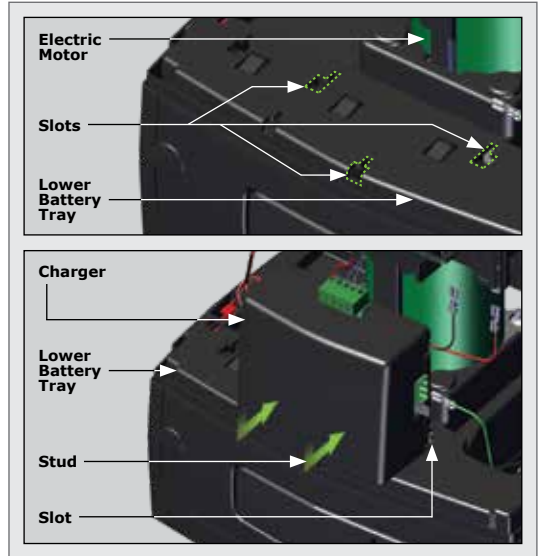

FIGURE 71. CHARGER PLACEMENT

7.10.4. Placing the Control Card back into Position

Tilt the control card and align the wider gap with the clips shown in Figure 72.

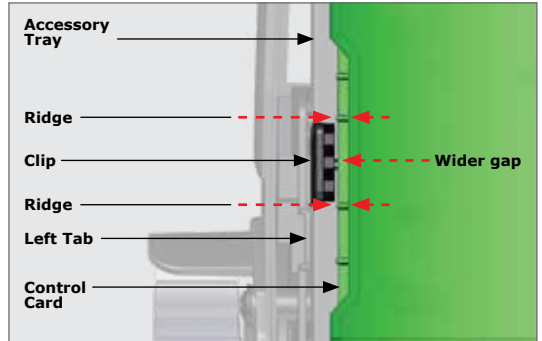

FIGURE 72

Once aligned, hinge the Control Card under the tab's lip, and firmly press downward on both sides in front of the Control Card.

This will engage the Control Card into the hinges at the front of the Accessory Tray.

A click from both sides will be heard if this is done correctly.

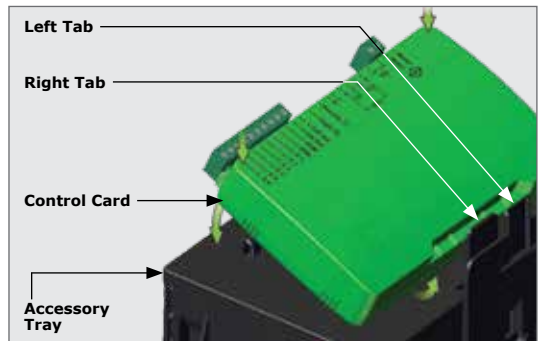

FIGURE 73

7.10.5. Reconnecting the Harnesses to the Control Card and Charger

Reconnect the Motor Wires at Position "A" and the Override Harness at Point "B" on the Control card.



The black motor wire is connected on the far Left of the Control Card, and the blue on the immediate right of the black.

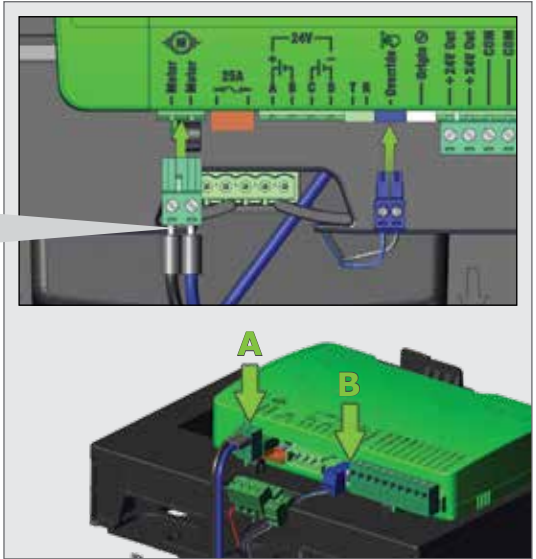

FIGURE 74

Reconnect the Charger Harness to the point from which it was disconnected earlier, either at Position "C" or at Position "D".



If the connection is made at Point "C", note that there are two connector blocks that need to be reconnected to the Control Card.



Utilise the Cable Retainers at the bottom of the accessory storage to neaten up the wiring, and the overall installation.

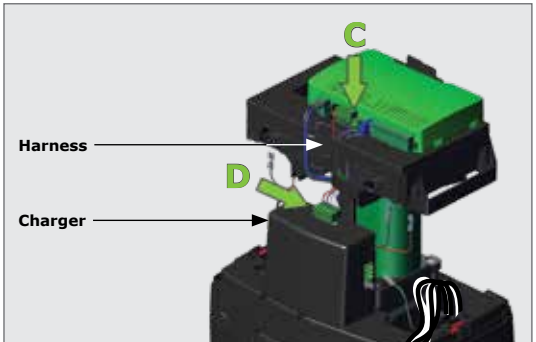

FIGURE 75

Connect the Earth Harness into the right-hand side of the Charger at Point "E".

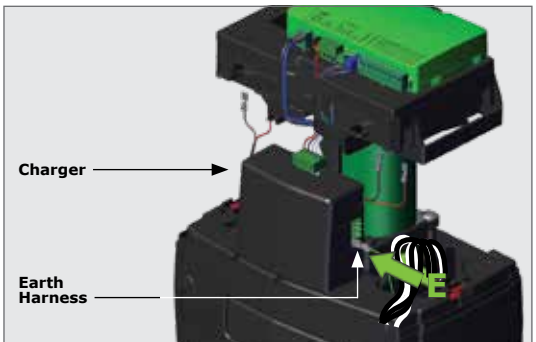

FIGURE 76

8. Completing the Installation

8.1. Fitting the Batteries

Gently push the left tab behind the Control Card backwards. This will allow the entire upper assembly to hinge forward.

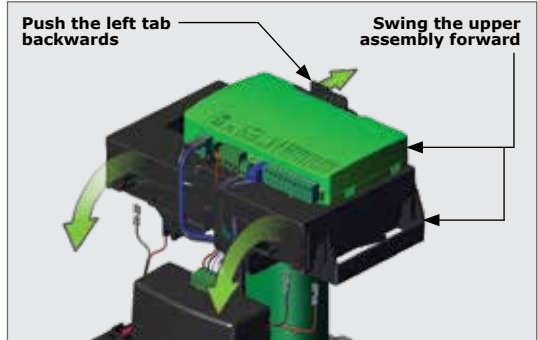

FIGURE 77

Place a Battery into the designated area found on top of the Lower Battery Tray on the left. Route the Power and Signal cables between the right Battery compartment and the Electric Motor then place the remaining Battery in it's designated area on the right.



Note the orientation of the two Batteries. Ensure that the Battery Terminals always face the direction of the Charger.

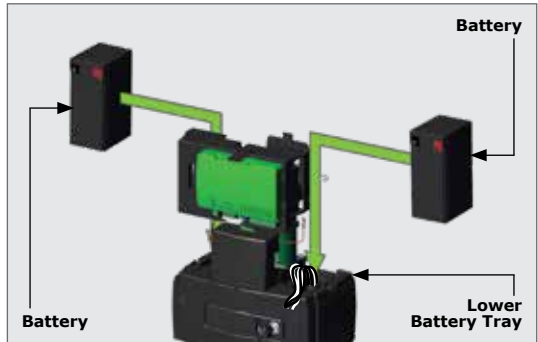

FIGURE 78

Take extra care not to pinch the Earth Harness when placing the Battery on the right. The Earth Harness must be routed under this Battery and out the gap found in front of the Battery once in position.



Swing the upper assembly back into position over the batteries.

A click should be heard if this is done correctly.

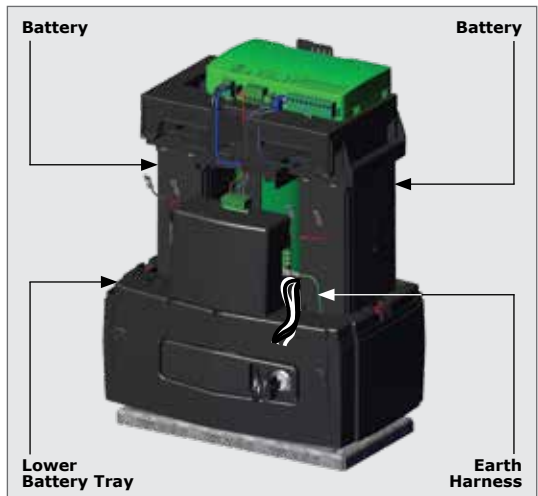

FIGURE 79



Failure to properly click the control card and upper assembly into place will result in erratic behavior of the gate motor.

Connect both batteries up with the supplied harness, and ensure that it is connected to the left side of the Charger.

Route the accessory cables around the back of the Charger and through the cable retainers found in front of the Control Card.



Please ensure that the battery connections match the selected battery terminals RED to RED, BLACK to BLACK.

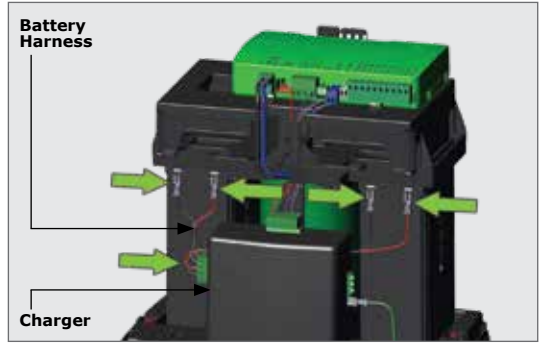

FIGURE 80

8.2. Accessory Installation and Storage

There are dedicated trays below the **D5 SMART** Control Card to conveniently install and store any accessories connected to the Operator.

Opening the two retaining doors, reveal the storage space for accessory products, such as the G-ULTRA, or External Receivers.

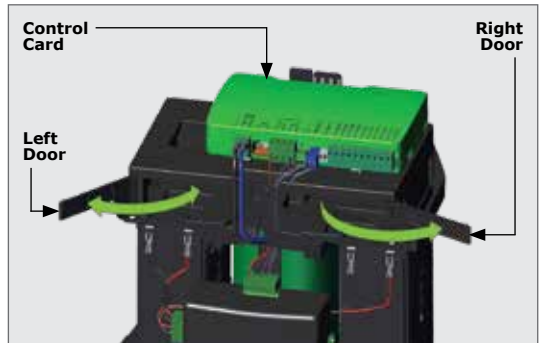

FIGURE 81

Wire the accessory device to the operator, place it into the space provided, and close the door.

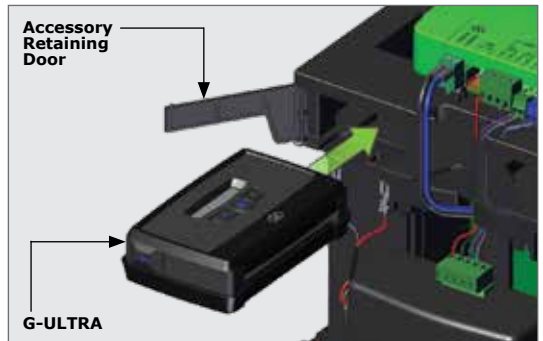

FIGURE 82

8.3. Wiring the Control Card on its Default Settings

The **D5 SMART** Control Card's Input / Output terminals are defaulted with the following configuration;

Control Card Terminal	Default Setting	Control Card Terminal	Default Setting
I/O1	Trigger (TRG)	I/O4	Gate Status
I/O2	Pedestrian (PED)	I/O5	Free-exit (FRX)
I/O3	Infrared Beam Close (IRBC)	I/O6	Safe Common

TABLE 2

8.3.1. Closing Infrared Beam Wiring (15 Infrared Beams)

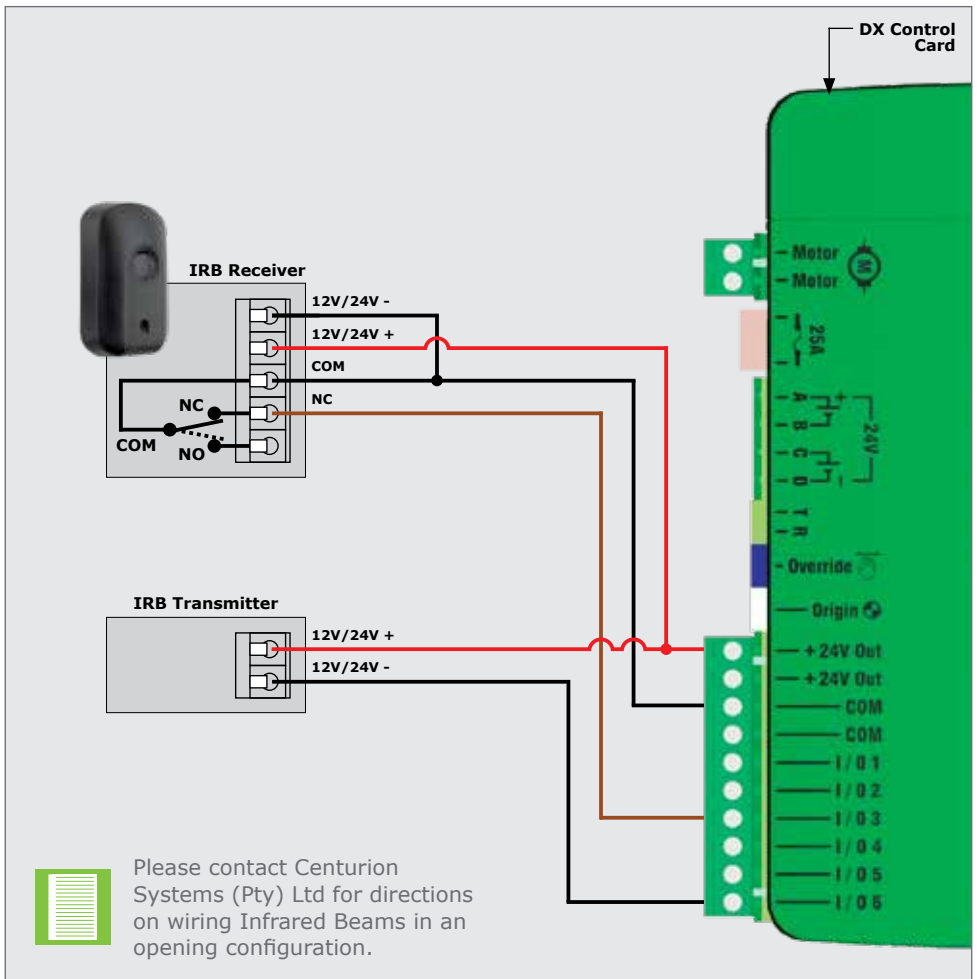

FIGURE 83

8.3.2. Closing Infrared Beam Wiring (Photon Infrared Beams)

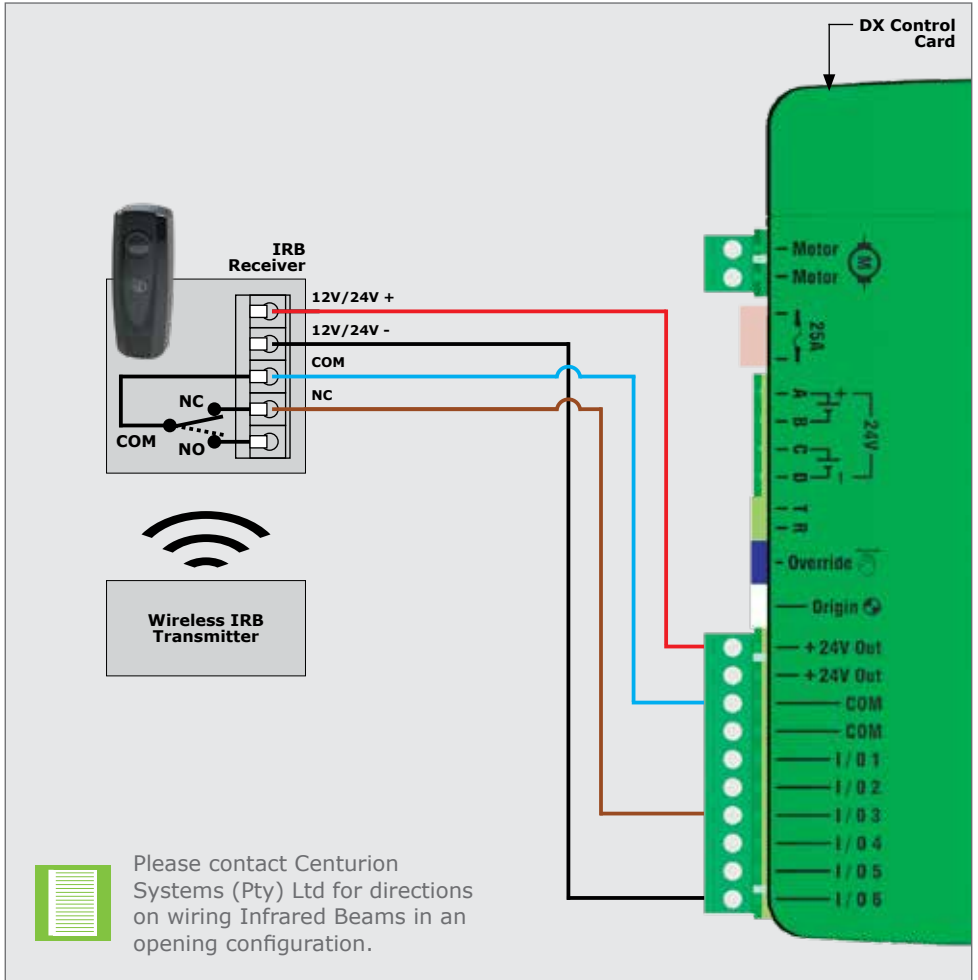

FIGURE 84

8.3.3. External Radio Receiver and Loop Detector Wiring

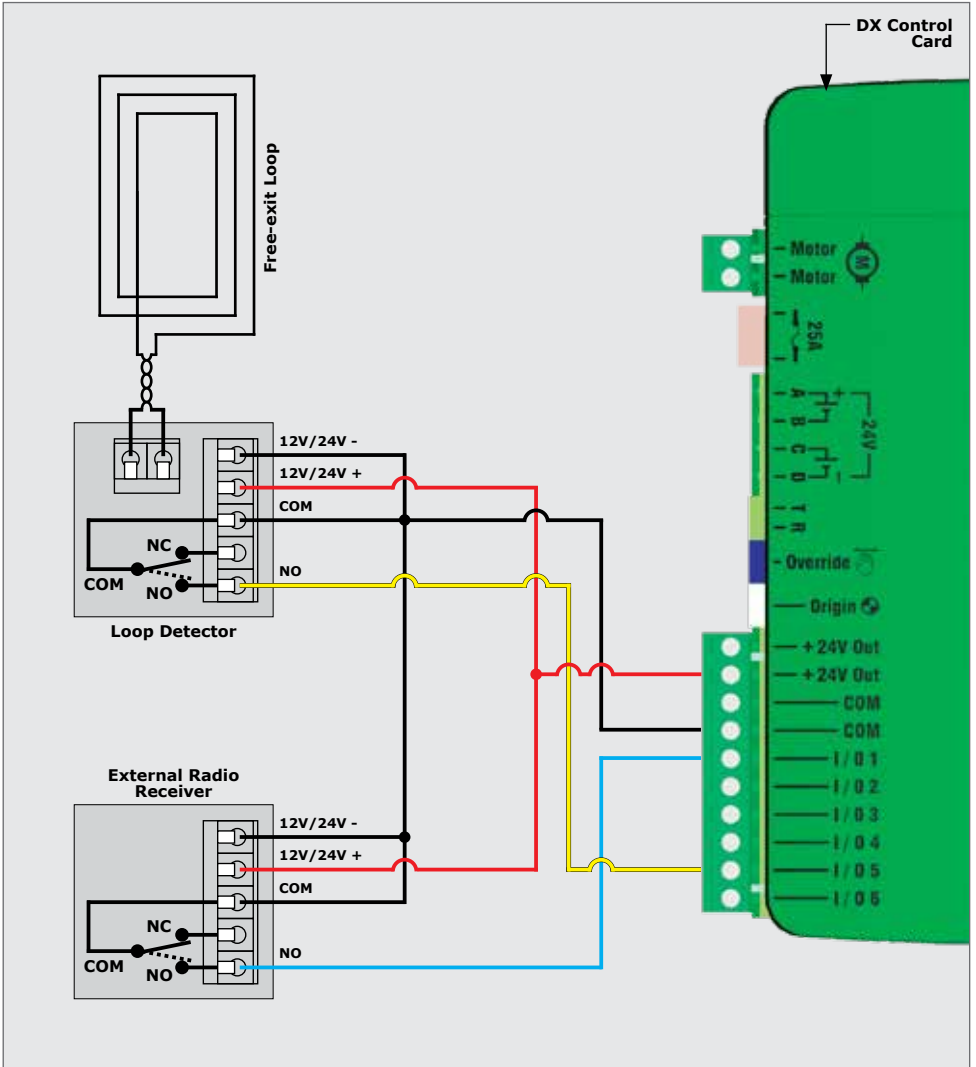

FIGURE 85

8.3.4. Anti-tamper Alarm with two Wizo's Wiring



- The trigger/TRG (green wire) in Figures 86 can be either wired into IO1 - IO6, depending on the sites individual needs
- IO1 - IO6 can be configured using the MyCentsys Pro mobile application
- IO1 is configured as trigger/TRG by default

Two WiZo-Link wireless modules may be connected to the system for a signal to be wirelessly relayed to a third party alarm in the event that the anti-tamper input is triggered.

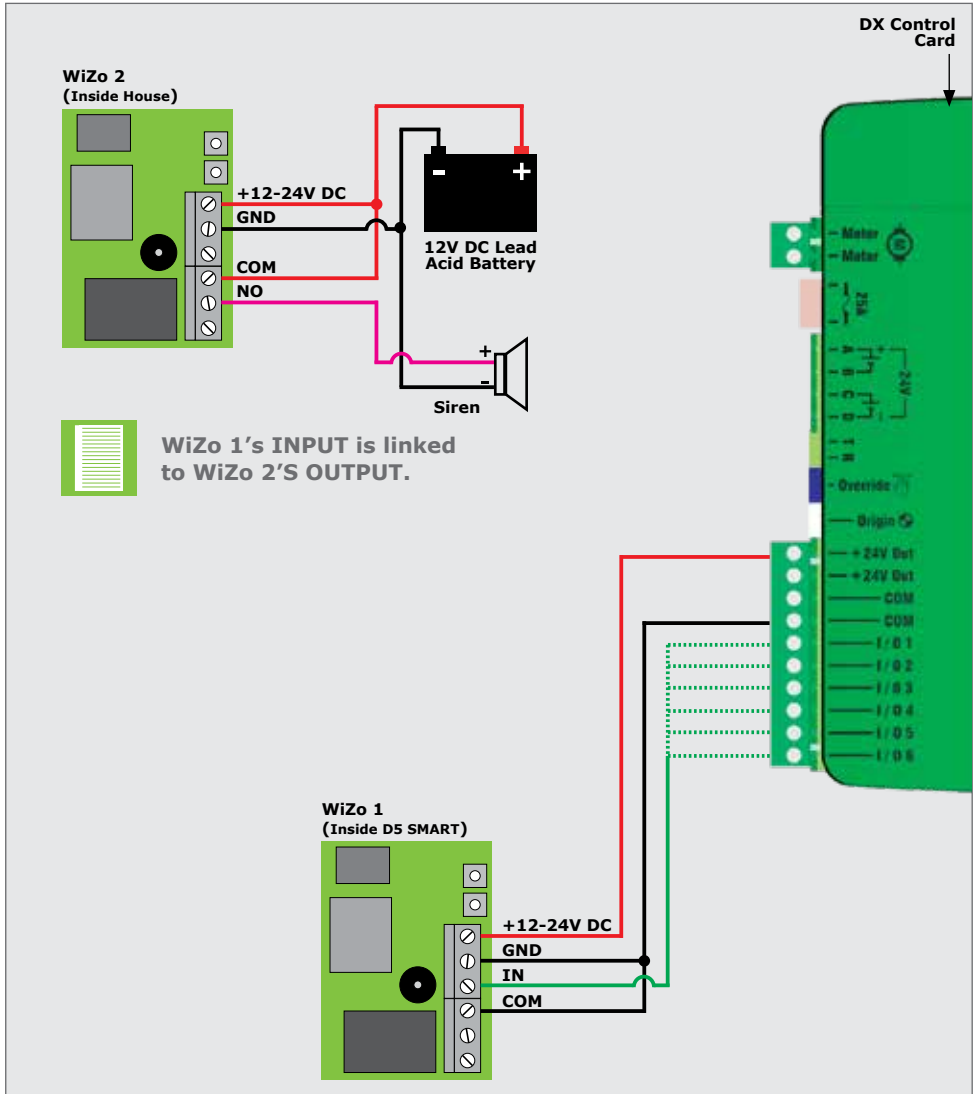

FIGURE 86. ANTI-TAMPER ALARM WIRING WITH TWO WIZOS

8.3.5. Solar Panel Wiring

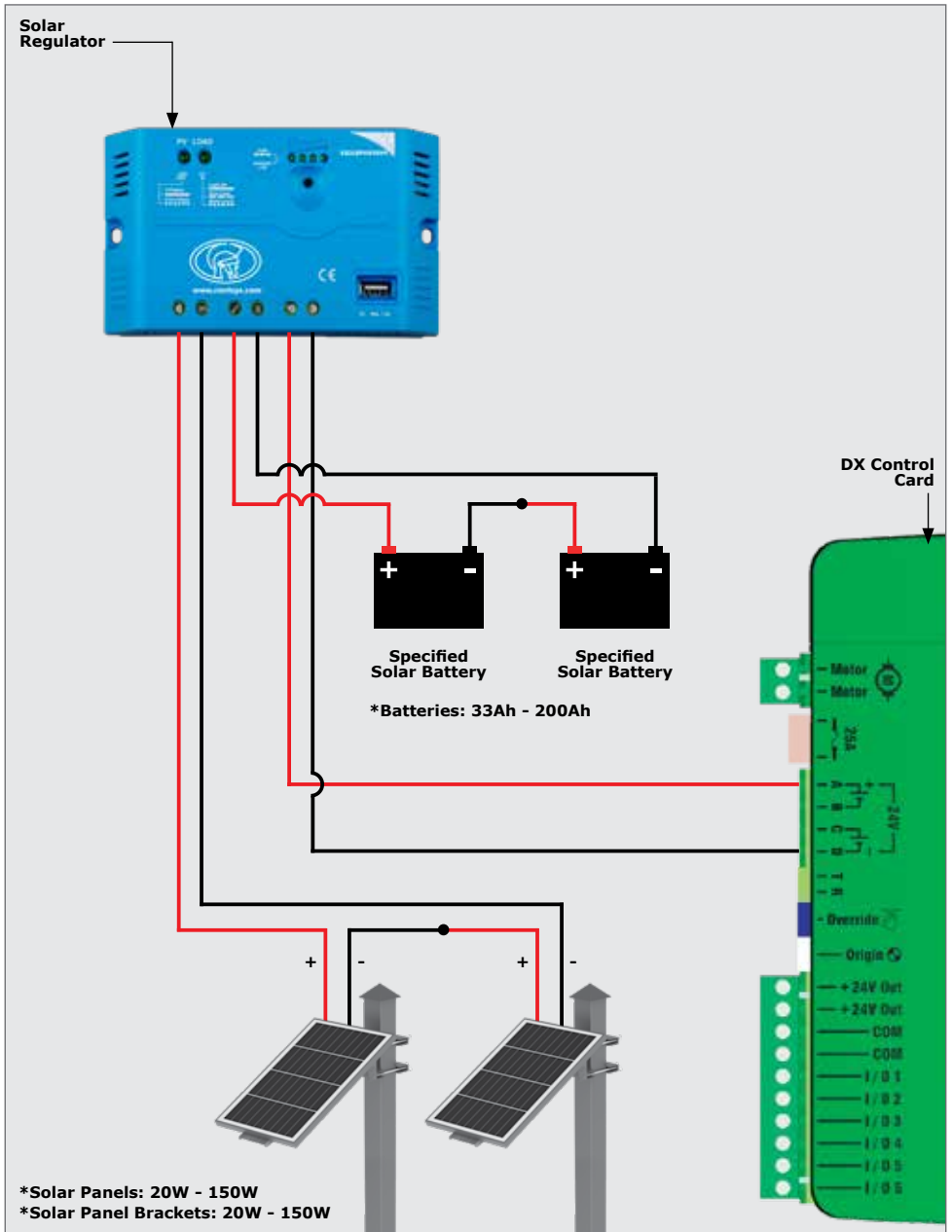

FIGURE 87

8.3.5. Earth Spike Installation

For further surge protection, an Earth Spike¹ can be installed. Route the earth cable from the Earth Spike around to the back of the **D5 SMART**, and under the Gearbox by the Cable Shield. Connect it to the Mounting Bolt on the right of the Gearbox where the Charger Earth is located by means of a Ring Lug. See Section 7.9.2.1. - "Placing and Routing the Earth Harness".



Utilise the Cable Management Clip to keep the wiring neat and out of the way.

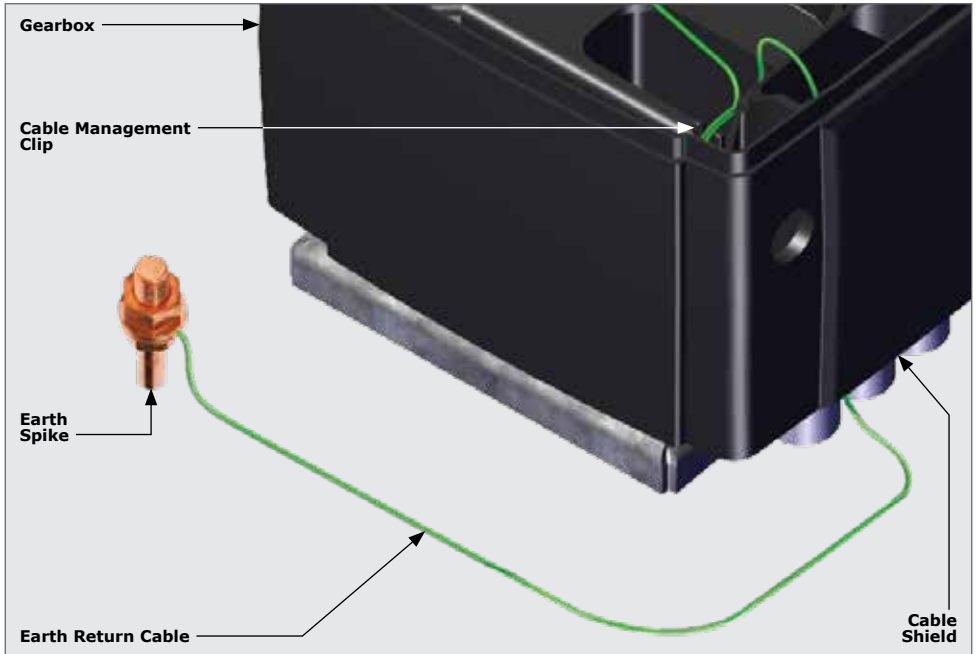

FIGURE 88

1. Not supplied with the **D5 SMART**.

8.3.6. G-ULTRA to D5 SMART Wiring

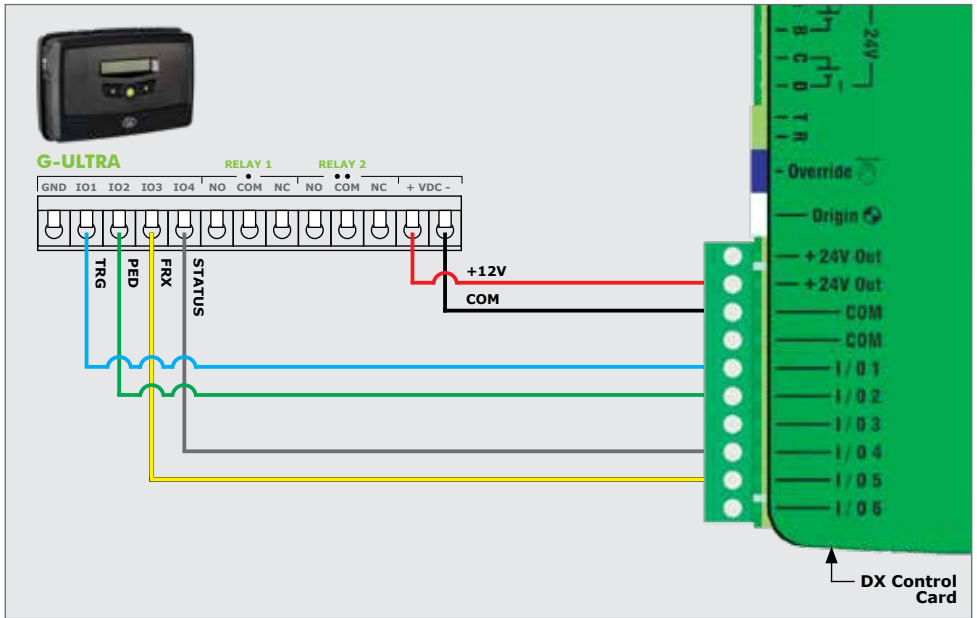

FIGURE 89

8.4. Commissioning the System

1. Scan the QR Code in Figure 89.
2. Select the App Store applicable to the operating system being used, either Apple App Store, Android Google Play Store or the Huawei App Gallery.
3. Download and install the application.

The figure shows a QR code for scanning. To the right, there are three app store download buttons: 'Download on the App Store', 'EXPLORE IT ON HUAWEI AppGallery', and 'Get it on Google play'. Below the App Store button, the 'Minimum Requirements' are listed: BLE-enabled mobile phone, iPhone 6s and above, and iOS13. Below the AppGallery button, the 'Minimum Requirements' are listed: BLE-enabled mobile phone and Android 5.0. (Lollipop).

FIGURE 90

Alternatively, go directly to the app store of the operating system being used, and search for the app "**MyCentsys Pro**". Download and install the application onto the smartphone.

1. Once installed, open the application.
2. From the list of operators, select the operator that is applicable to this installation.
3. Connect to the relevant operator.
4. Use the app by following the prompts to configure the **D5 SMART**.

SECTION 8

Once all the necessary accessories and harnesses have been connected, ensure that the Camlock is in the "unlocked" position, and place the **D5 SMART** cover onto the gearbox.

Once the cover is secured in place, lock the Camlock to lock the cover in place.

COMPLETING THE INSTALLATION

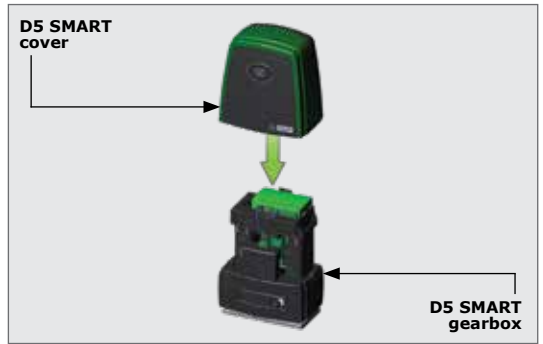

FIGURE 91

8.5. Applying the Warning Decal

Apply the supplied warning decals to the gate as indicated on the reverse side of the decal.



FIGURE 92

9. General Maintenance

9.1. Gate Maintenance

Description	Frequency	Corrective Action
Ensure that the gate track is clear of debris at all times	Daily	Clean around the gate and gate operator. Consider installing gate brooms on the bottom of the gate
Ensure that the endstops are sturdy and secure	Every 3 months	If the endstops are damaged or loose, contact an installer to replace
Check that the rack is securely mounted to the gate over its full length	Every 3 months	Contact installer
Contact an installer to inspect and verify that all safety equipment, e.g. safety beams, is functioning correctly	Every 6 months	N/A
Ensure that the gate moves smoothly when in Manual Override. Check wheels and guide-rollers for signs of wear	Every 6 months	Place the motor in Manual Override and manually open and close the gate. If the wheels and/or guide-rollers are excessively worn, contact an installer to replace
Check the track for damage or corrosion	Every 6 months	If the track is damaged, contact an installer to replace
If pedestrian gate / emergency gate is fitted within the main gate, ensure that the lock operates smoothly	Every 6 months	Dry lubricate if necessary (graphite)

TABLE 3

9.2. D5 SMART Maintenance



Before performing any maintenance, ensure that the D5 SMART is isolated!

Description	Frequency	Corrective Action
Check for insect infestations	Every 3 months	<p>Clean and remove any nests that are settling in and around the motor and Control Card</p>  <p>Insert a moth ball, which may help to repel insects, at the bottom of the gearbox</p>
Check that the M10 half-nuts are tight on the foundation plate bolts	Every 6 months	Torque setting 20Nm
Check that there is no sand build-up inside the unit	Every 6 months	Remove batteries and lower battery tray and clear out the sand build-up
Check pinion and rack engagement	Every 6 months	If the mesh is too loose or the rack is riding on the pinion, contact an installer to correct
Check the condition of the pinion	Every 6 months	If the pinion is excessively worn, contact an installer to replace
Check the condition of the override cam lock	Every 6 months	Dry lubricate if necessary (graphite)
If used, check the condition of the theft-deterrent cage	Every 6 months	Ensure that the device is serving its purpose
If used, check the condition of the theft-deterrent cage lock and that it operates	Every 6 months	Dry lubricate if necessary (graphite)

TABLE 4

10. Installation Handover

Once the installation has been successfully completed and tested, it is important for the installer to explain the operation and safety requirements of the system.

NEVER ASSUME THE USER KNOWS HOW TO SAFELY OPERATE AN AUTOMATED GATE!

Even if the user has used one before, it does not mean they know how to SAFELY operate it. Make sure that the user fully understands the following safety requirements before finally handing over the site.

The following needs to be understood by the user:

- How to operate the Manual Release mechanism.
(Show them how by demonstration)
- How the obstruction detection and all other safety features work.
(Show them how by demonstration)
- All the features and benefits of the Operator, i.e. Beams, etc.
- All the safety considerations associated with operating an automated gate. The user should be able to pass this knowledge on to all other users of the automated system and must be made aware of this responsibility.

- Do not activate the Gate Operator unless you can see it and can determine that its area of travel is clear of people, pets, or other obstructions
- **DO NOT CROSS THE PATH OF A MOVING GATE.** Always keep people, pets and objects away from a moving gate and its area of travel
- **NEVER LET CHILDREN OPERATE OR PLAY WITH THE GATE CONTROLS,** and do not allow children or pets near the gate area
- Avoid close proximity with moving parts where fingers, hands or clothing could be pinched and caught
- Secure all easily-accessible gate operator controls in order to prevent unauthorised use of the gate
- Keep the automated gate system properly maintained, and ensure that all working areas are free of debris and other objects that could affect the gate operation and safety
- On a monthly basis, check the obstruction detection system and safety devices to ensure correct operation
- All repair and service work to this product must be done by a suitably qualified person
- This product was designed and built strictly for the use documented herein. Any other uses not included herein, could compromise the operating condition of the product and/or be a source of danger!



Centurion Systems (Pty) Ltd does not accept any liability caused by improper use of the product, or for use other than that for which the automated system was designed. **Ensure that the customer is in possession of the User Guide and that you have completed the installation details in the back of the User Guide.**

11. Warranty Information



You can register your product(s) online at www.centsys.com, which will assist you in keeping a record of your date of purchase or installation, serial numbers, etc.

All of our products are manufactured with extreme care, thoroughly inspected and tested.

The goods supplied by us shall be subject to the provisions of sections 55 to 57 of the Consumer Protection Act (68/2008) except where the provisions of the warranty contained in our product documentation are more favourable to the purchaser. Subject to the warranty contained in our product documentation, if applicable, our products are warranted for a period of twenty-four months after delivery. However, it is expressly noted that batteries carry a six month warranty due to the nature of these products being such that they are subject to possible misuse. Please note that warranties will be honoured on a carry-in basis; in other words, the product in question must be taken in to one of our branches, or to the authorised reseller that the product was purchased from, for assessment and, if necessary, repair. For equipment not of our manufacture, the warranty as supplied by the original manufacturer will apply if such warranty is more favourable to the purchaser than the relevant provisions of the Consumer Protection Act (Act 68/2008 of South Africa), or any other applicable law as so required in different countries in which the product was sold. Such warranty is valid only once full payment has been received for such goods.

Australian customers:

Our goods come with guarantees that cannot be excluded under the Australian Consumer Law. You are entitled to a replacement or refund for a major failure and compensation for any other reasonably foreseeable loss or damage. You are also entitled to have the goods repaired or replaced if the goods fail to be of acceptable quality and the failure does not amount to a major failure

Any warranty may be voidable on any equipment which:

1. Has not been installed in accordance with the installation instructions provided.
2. Has been subject to misuse or which has been used for any purpose other than that designed for by the manufacturers.
3. Has damage caused as a result of handling during transit, atmospheric conditions (including lightning), corrosion of metal parts, insect infestation, power surges or other forces outside of the control of the manufacturer.
4. Has been repaired by any workshop and / or person NOT previously authorised by the manufacturer.
5. Has been repaired with components not previously tested, passed or authorised by Centurion Systems (Pty) Ltd, South Africa or one of its subsidiary companies.